



*INSTALLATION AND
SERVICE MANUAL*



Model 550, 700 and 900 Water Softeners

Version 4

WaterBoss® 4343 S. Hamilton Road, Groveport, Ohio 43125

Table of Contents

QUESTIONS?	1
GETTING MAXIMUM EFFICIENCY FROM YOUR APPLIANCE	2
CHECKLIST BEFORE INSTALLATION.....	3
DO'S AND DON'TS	4
REFERENCE ILLUSTRATIONS	5
CYCLES	10
INSTALLATION AND START-UP PROCEDURES	11
SETTING THE 4 BUTTON CONTROLLER	13
ADVANCED SETTINGS FOR THE 4 BUTTON CONTROLLER	14
CARE, MAINTENANCE AND PARTS	16
SPECIFICATIONS/CAPACITY CHART	25
TROUBLESHOOTING	26
LIMITED WARRANTY	28
NOTES	29

**When calling the HelpLine, please have this guide and the serial number available. From 8 am to 5 pm EST, call 1-800-437-8993.
Your serial number may be found on top of your valve assembly.**

Questions

From 8 am to 5 pm EST, use the 800 HelpLine: 1-800-437-8993

The HelpLine is available to help answer questions about specific water problems, appliance installation and operation. When calling the HelpLine, please have this guide and the serial number of your appliance available. Your serial number may be found on top of your valve assembly (See figures 2-3.)

Date of Installation: _____

Model Number: _____

Serial Number: _____

Returned Limited warranty Card Date: _____

**When calling the HelpLine, please have this guide and the serial number available. From 8 am to 5 pm EST, call 1-800-437-8993.
Your serial number may be found on top of your valve assembly.**

How To Get The Maximum Efficiency From Your Appliance

1. Fill salt cabinet when water level is above salt level. **DO NOT MIX DIFFERENT TYPES OF SALT.** If iron is present in your water, use a salt with an iron-cleaning additive to help keep resin clean. You may also use a resin cleaner on a monthly basis in place of salt with cleaning additives. If iron is not present in your water, a clean pellet, solar or cube type salt is recommended. The use of rock salt is not recommended because it contains impurities that can plug up the injector assembly.
2. You may use a salt substitute (such as potassium chloride) in place of water conditioner salt. If you start with water conditioner salt, you can switch to a salt substitute at any time - or vice versa. If potassium chloride is used in place of nugget or pellet salt, increase your hardness setting by 12% (multiply by 1.12). Do not use Potassium Chloride if there is iron in your water.
3. Should your electricity be turned off for any reason you must reset the time of day if you programmed your appliance for delayed regeneration.* (see page 14)
4. Protect your appliance from freezing, including drain line.
5. By-pass the appliance when servicing the well, plumbing, or pump. When work is completed, turn on the nearest cold water tap until water runs clear before putting appliance back in service. See figures 4 - 5 - 6.
6. Install after the pressure tank.

**When calling the HelpLine, please have this guide and the serial number available. From 8 am to 5 pm EST, call 1-800-437-8993.
Your serial number may be found on top of your valve assembly.**

Checklist Before Installation

1. **Water Pressure** - Not less than 20 psi constant for softeners.
2. **Double check hardness** - of water with test strips provided to verify that your appliance is right for the job.
Model 550 FOR MUNICIPALLY-SUPPLIED WATER is for water without iron and up to 25 grains of hardness per gallon.
Model 700 for up to 70 grains hardness per gallon.
Model 900 for up to 90 grains hardness per gallon. (See specifications, page 30.)
3. **Water Supply Flow Rate** - 5 gallons per minute is recommended as minimum.
4. **Drain** - Drain appliance to floor drain or washer drain. To prevent back-siphoning, the installer must provide an adequate air gap or a siphon break. See figure 1.
5. **Electricity** - The transformer supplied is a standard 120 volt, 60 cycle A.C. for USA or 220 volt, 50 cycle A.C. for outside the USA. See figure 8.
6. **Water Quality** - If the water supply contains sulfur, bacteria, iron bacteria, tannins, algae, oil, acid or other unusual substances, then unless the appliance is represented as being capable of treating these contaminants in the specifications, other special treatment of the water supply must be used to remove these contaminants before they enter this product.

If you have any questions call our HelpLine!

**When calling the HelpLine, please have this guide and the serial number available. From 8 am to 5 pm EST, call 1-800-437-8993.
Your serial number may be found on top of your valve assembly.**

Do's And Don'ts

SOME DO'S

1. Do comply with all local plumbing and electrical codes.
2. Do install pressure-reducing valve if inlet pressure exceeds 90 psi.
3. Do install gravity drain on salt storage cabinet. See figure 7.
4. Do secure drain line on appliance and at drain outlet. See figure 3.
5. Do allow a minimum of 8 to 10 feet of 3/4" pipe from the outlet of the water conditioner to the inlet of the water heater. See figure 1.

SOME DON'TS

1. Do not install if checklist items are not satisfactory.
2. Do not install if incoming or outlet piping water temperature exceeds 120 degrees Fahrenheit. Please see specification on page 25.
3. Do not allow soldering torch heat to be transferred to valve components or plastic parts. See Installation Tip, page 6.
4. Do not overtighten plastic fittings.
5. Do not place appliance right up against a wall which would deny access to plumbing. See figure 1.
6. Do not install the appliance backwards. Follow arrows on inlet/outlet. See figure 2.
7. Do not plug the transformer into an outlet that is activated by an on/off switch. See figure 8.
8. Do not connect the drain and the overflow (gravity drain) together. See figure 1.

**When calling the HelpLine, please have this guide and the serial number available. From 8 am to 5 pm EST, call 1-800-437-8993.
Your serial number may be found on top of your valve assembly.**

Reference Illustrations

Figure 1 - Installation Guide

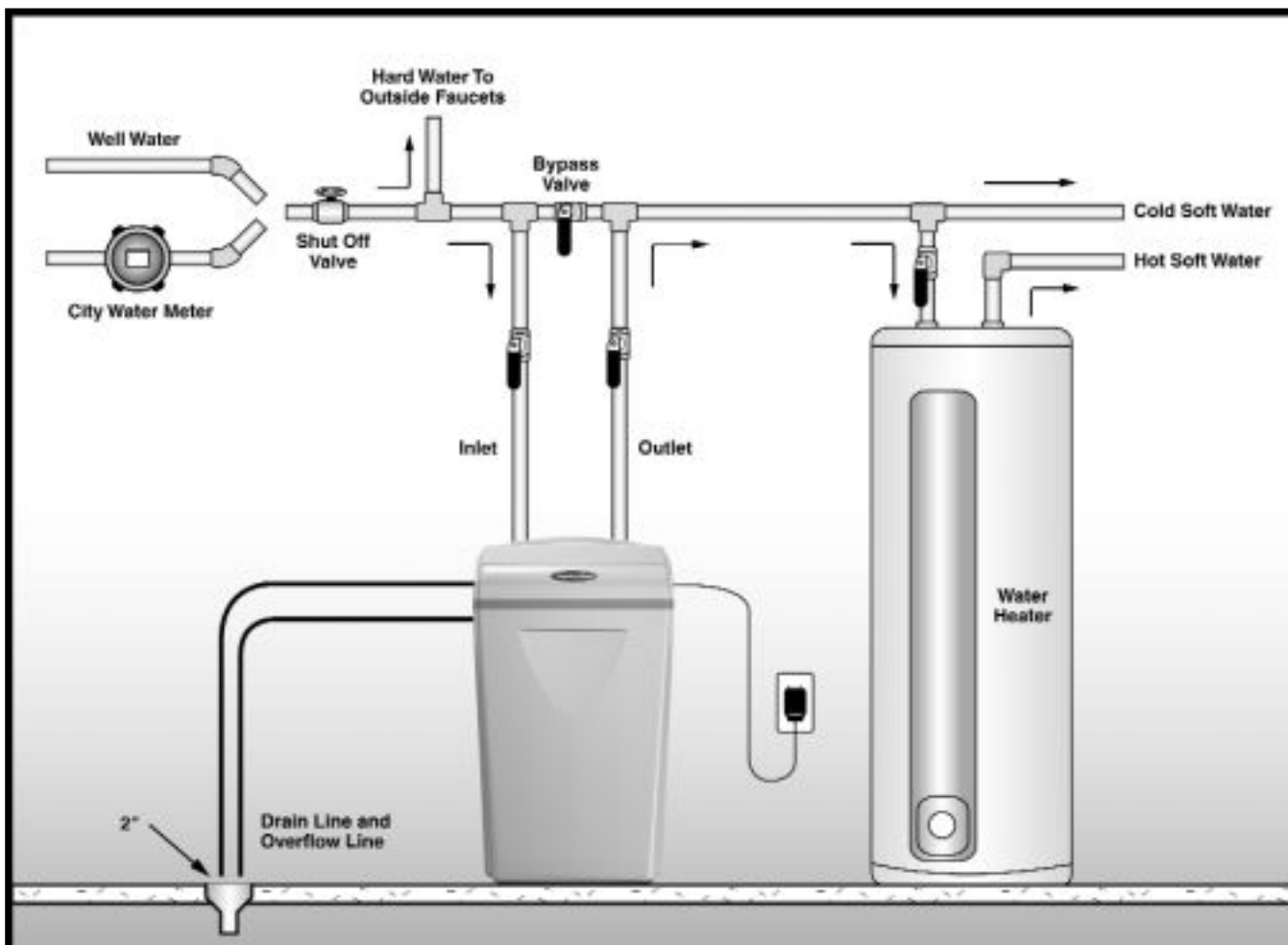

Use this diagram as a location and installation guide for your **Model 550**, **Model 700**, and **Model 900** water conditioners. This diagram applies to all types of installations (i.e. basement, slab, crawl space, outside).

Bypass Valves. To simplify installation and servicing, a one-piece or a three way bypass valve appliance is recommended when installing your appliance. A bypass appliance also provides access to untreated water when required (i.e. for lawn and gardening purposes.) Also, see figures 4 through 6.

Caution: If less than 10 feet of pipe connect the water treatment appliance(s), to the water heater, then a Check Valve must be installed between the water treatment appliance and the water heater. Install the Check Valve as close to the water heater as possible.

When calling the HelpLine, please have this guide and the serial number available. From 8 am to 5 pm EST, call 1-800-437-8993. Your serial number may be found on top of your valve assembly.

Reference Illustrations

Figure 2
PLUMBING CONNECTIONS



Teflon® Tape

Figure 3
CONNECTING DRAIN LINE



CAUTION! The drain line must not be kinked, crimped or restricted in any way. The drain line should be a minimum 1/2" inside diameter and cannot be reduced in size.

INSTALLATION TIP

When preparing the male threaded fittings of the I/O adapter, follow the guidelines to avoid damage to the plastic pipe threads.

1. For best results, use 1/2" wide Teflon® tape and wrap the threads three times with each consecutive wrap on top of the previous wrap. To prevent tearing of the the tape, use Teflon® paste on the first two threads only. This lubricates the tape and fills the small void areas that may exist between the threads. When the joint is complete, there will be a small bead of sealant at the fitting interface indicating a properly joined connection.
2. When preparing copper fittings, it is always advisable to use a union where there is a threaded connection to facilitate repairing a potential leak in one of your soldered joints.
3. To prevent heat damage to the plastic pipe threads of the adapter, prepare the copper tail assemblies ahead of time so they can cool down before final assembly. The copper tube length should be a minimum of 3-1/2" long. To prevent cross threading, turn the fitting counterclockwise until you feel the threads engage, then tighten. Do not overtighten the fittings.

CAUTION NOTE: To avoid damage, do not allow heat from the torch to be transferred to the plastic valve component.

Reference Illustrations

Figure 4 - Bypass Valve

Optional Bypass Valve Part #93884 may be available through your local hardware store, plumber or call our HelpLine **1-800-437-8993** From 8 am to 5 pm EST. to order.

<push/pull>
for service or bypass.

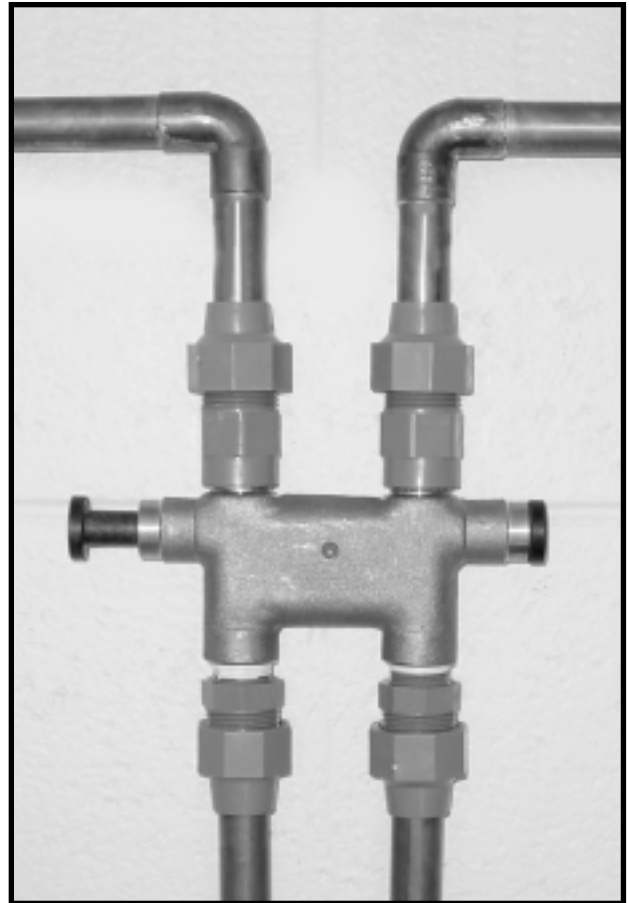

*Figure 5 -
In Bypass Position*

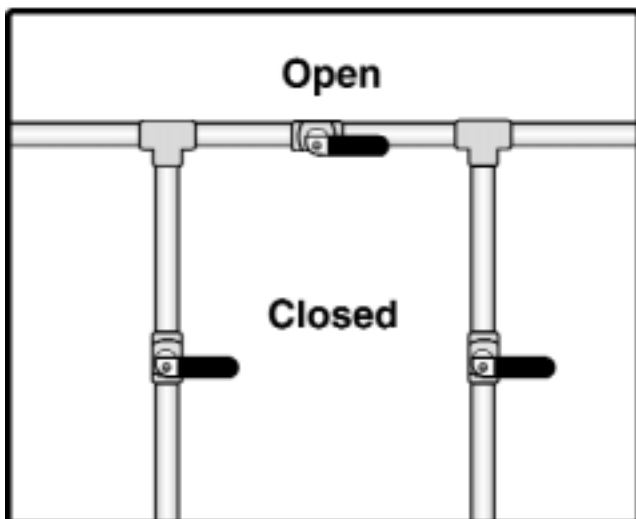

*Figure 6 -
In Service Position*

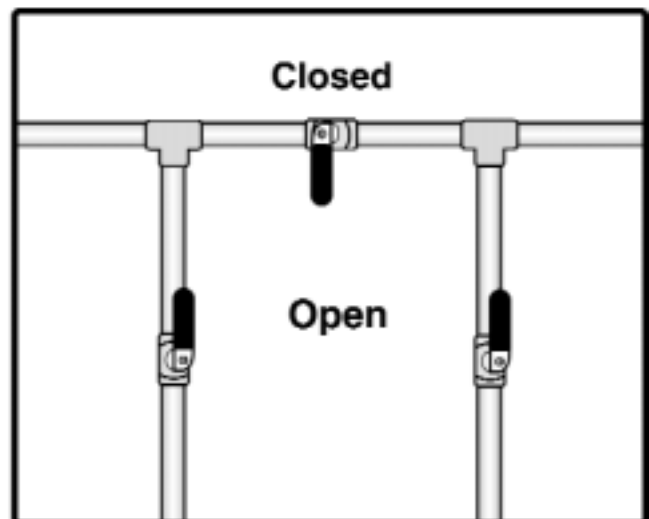

Reference Illustrations

Figure 7

OVERFLOW
CONNECTION
(1/2" I.D.)

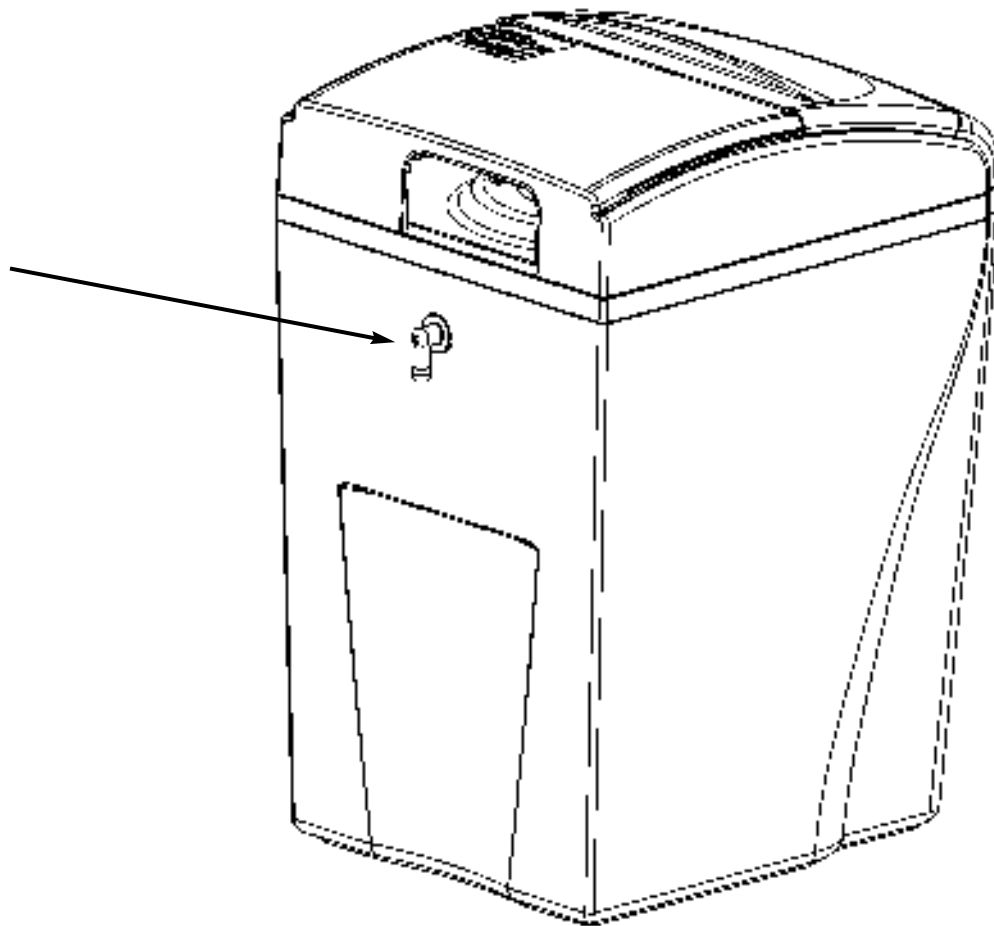

Figure 8



PLUGGING IN TRANSFORMER

Do not plug transformer into an outlet that is controlled by on/off switch.

When calling the HelpLine, please have this guide and the serial number available. From 8 am to 5 pm EST, call 1-800-437-8993. Your serial number may be found on top of your valve assembly.

Reference Illustrations

Figure 9



Figure 10

ADDING SALT TO
THE BRINE CABINET

Cycles

Water by-passes your appliance during regeneration to allow iron, sediment, hardness, etc. to be washed down the drain. After regeneration, the appliance returns to service, providing your home with treated water.

Regeneration cycles:

1. First up-flow backwash. A rapid up-flow of water flushes out the resin bed and cleans the sediment filter.
2. Brine. Brine is drawn out of the brine cabinet and up through the media tank, cleaning the resin bed and releasing accumulated hardness and iron.
3. Slow rinse. A slow up-flow rinse process then flushes out the brine, hardness and iron.
4. Second up-flow backwash. This up-flow backwash flushes out any remaining brine solution and sediment from cycle 2.
5. Downflow soft water brine refill. Soft water is directed to the brine cabinet to prepare the brine for the next regeneration sequence.
6. Return to service. Regeneration is complete and the appliance is returned to normal operation.

**When calling the HelpLine, please have this guide and the serial number available. From 8 am to 5 pm EST, call 1-800-437-8993.
Your serial number may be found on top of your valve assembly.**

Installation And Start-Up Procedures

Each water conditioning appliance includes water test strips and 8' of drain line.

CAUTION: Be sure the controller is firmly “locked” onto the drive end cap assembly. The four tabs on top of the drive end cap will allow the clips on the bottom of the controller case to lock onto the end cap tabs. (See detail diagram on page 16. Fig. 11.)

1. Placement: Place your appliance in desired location. Turn off electricity and water supply to water heater. Make sure inlet/outlet and drain connections meet the applicable local codes. Check arrows on valve to be sure water flows in proper direction. See figures 1, 2, & 3.

CAUTION: DO NOT PLUMB APPLIANCE IN BACKWARD. See page 6

2. Drain Line: must be a minimum of 1/2"-5/8" I.D. tubing and should make the shortest run to a suitable drain. The drain line may be elevated up to 8 feet from the discharge on the appliance as long as the water pressure in your appliance is 40 psi or more. If drain line is 25' or longer, increase drain line to 5/8" I.D. Also, the end of the drain line must be equal in height or lower than the control valve. See figure 1.

3. Flushing: Before placing your appliance in service, it is very important to flush the cold water lines of any debris. Turn on water supply, open the nearest cold water tap and let the water run for 2 to 3 minutes or until the water flows clear. Then put the by-pass in the Service position. See figures 4 through 6.

4. Check Leaks. Close faucet and check for leaks. If leaks are found, turn off main water supply and open the nearest cold water faucet to depressurize lines. Close faucet to eliminate siphoning action. Repair leaks. Turn on water supply and electricity to water heater. Place the bypass valve in the Service position. See figures 4 and 6.

5. Connect Overflow Line. The overflow line must end at a drain that is at least 3" lower than the bottom of the overflow fitting. It is a gravity line and cannot be run overhead. See figure 7.

6. Complete The Installation. Open a cold water tap and allow the appliance to flush for 20 minutes or until approximately 72 gallons has passed through the appliance per NSF requirements.

7. Plug In Transformer. See figure 8.

**When calling the HelpLine, please have this guide and the serial number available. From 8 am to 5 pm EST, call 1-800-437-8993.
Your serial number may be found on top of your valve assembly.**

Installation And Start-Up Procedures

8. Setting Number. For **Models 700, 900, and 550** for municipally-supplied water, determine your controller setting number. Do not guess at the setting; continued water quality problems or damage to the appliance could result.

Municipal water - call your local water company to determine your water hardness in grains per gallon. This will be your setting number. Or, follow the instructions on the hardness test strip provided with your **Model 550** to determine your hardness reading. This will be your setting number.

Well water - follow the instructions on the pH and hardness test strips provided with your appliance to determine the pH and hardness of your water.

Iron adjustment: if pH is 7 or above and you know your water has iron, add 15 to your hardness reading in grains per gallon and enter the result as your setting #.

Example: hardness in grains per gallon from test strip is 20 + 15 = 35 = setting #.
This is a temporary setting until you have an accurate water test.

If the result of your hardness test strip reaches the test maximum of 25 grains per gallon, mix 1 cup tap water with 1 cup distilled water, then retest for hardness. Multiply your reading x 2 and use this number as your setting number. If the test strip result is still 25 grains per gallon, call your HelpLine. Or, contact the company below to test for hardness, iron and pH.

WATERSCREEN
National Testing Laboratories, Inc.
1-800-458-3330 - 9 am - 5 pm EST

If you feel you have an abnormal amount of iron, push the powerClean® button for **Models 700 and 900** only. Also, be sure to use salt with an iron-cleaning additive. Be aware that model **Model 550** for municipally-supplied water is not designed to treat water with iron. If pH is below 7, Call your HelpLine.

9. Adding Water & Salt. Be sure to remove any packaging or installation materials before adding salt. Next, add no more than 2 gallons of water to the brine cabinet. Then add salt to the brine cabinet, wait 2 hours then push the immediate recharge button and hold for 5 seconds. A regeneration cycle will begin and continue as follows: **Model 900**, 48 minutes; **Model 550** for municipally-supplied water, 27 minutes; and **Model 700** 33 minutes. After the first regeneration, your softener will automatically refill the correct amount of water in the brine cabinet. See figure 10.

10. Refill Salt when the salt level drops below the water level in the brine cabinet. Always keep salt above water level. See figure 10

CAUTION! Failure to install, operate and maintain your water treatment appliance as instructed will VOID the product limited warranty.

NOTE! Make sure the Owner's Limited warranty Card is filled in and mailed within 30 days of installation. NO POSTAGE REQUIRED.

Setting The 4 Button Controller

DEMAND REGENERATION

You won't have to worry about vacation settings or extra guests because the controller measures water usage and regenerates based on need. The appliance will regenerate using only the necessary amount of water and salt. If power has been turned off, your appliance will retain programmed settings indefinitely. See figure 9.

1) ENTERING YOUR HARDNESS SETTING

See page 12 for determining your setting number. Push the "SET" button for about 5 seconds. Now, the water hardness setting number shown in the digital readout will increase 1 grain each time you push the "CHANGE" button. After 70 grains for **Model 700** (90 grains for **Model 900** and 25 grains for **Model 550**) the read-out will return to 03, and continue to count up until the display number matches the hardness number. Press the "SET" button to save the hardness number. To recheck the hardness, hold down the "SET" for about 5 seconds.

2) GALLONS REMAINING

After setting water hardness, gallons remaining until the next automatic regeneration is shown in the digital display. NOTE: Gallons remaining are in hundreds. 12=1,200 gallons

3) RECHARGE/REGENERATION STATUS

Regeneration cycle numbers are shown during regeneration. The read-out will flash with the cycle number. The flashing regeneration numbers are:

First cycle:	(01) First Backwash
Second & Third cycles:	(02) Brine/Slow Rinse
Fourth cycle:	(03) Second Backwash
Fifth cycle:	(04) Brine Refill
Sixth cycle:	(HO) Service

To quickly advance through the regeneration cycles, press and hold the Regenerate button for 2 seconds. Wait for the cycle to begin, after 20 seconds press and hold the Regenerate button until the cycle number changes (about 2 seconds.) Each cycle can be advanced in this manner.

4) waterMizer

The waterMizer® wheel will turn whenever water is being used. See figure 9.

5) REGENERATE

To start an immediate regeneration, press The "Regenerate" button and hold for 3 seconds. The Regenerate button is used when starting your water conditioner, to start an immediate regeneration, or to restore capacity if you have run out of salt. If your appliance has run out of salt, you may not have soft water available. Open the salt lid and add salt. Wait two hours, then press the "REGENERATE" button and hold for 3 seconds. See figure 9.

6) POWERCLEAN™

The powerClean™ feature is a service/maintenance step for water supplies that have an excessive amount of iron. Activating this feature is a simple push of the powerClean™ button on the controller. PowerClean™ will appear in the display when this feature is activated. The appliance will regenerate every other day with five pounds of salt. Leave the powerClean™ feature on for a minimum of two weeks. The frequent regeneration will eliminate iron buildup in the resin bed. The use of salt with an iron cleaning agent or iron out cleaner is recommended for continuous use as a preventive measure against iron fouling of the resin bed. To deactivate this feature, simply press the powerClean™ button. Use this feature every six months as a part of your routine maintenance procedure to insure a long service life for your water treatment appliance. See figure 9.

Setting The Controller - Continued

ADVANCED CUSTOMER SETTINGS:

Your appliance can be programmed for High Capacity (HC) or High Efficiency (HE). High Capacity means the appliance will regenerate less often, but use more salt. High Efficiency will make the appliance regenerate more often and use less salt. See Specification/Capacity Chart, pg. 25.

1. Hold down SET and CHANGE for 3 seconds to enter advanced customer settings mode. While SET and CHANGE are being held down, the display should show only the controller type. After the 3 seconds, the entire screen is lit for a half second, and then "HC" will appear.
2. Pressing and releasing the CHANGE button will toggle the digit display between "HC" and "HE". Pressing and releasing the SET button will advance programming to the next step. Default is "HC".
3. The controller will now display "Demand Mode." Each press of the CHANGE button will switch between "Demand Mode" and "Delayed Mode".

Delayed Mode allows regeneration at a specific time (e.g. at 2 am when less water is being used.) Demand Mode triggers a regeneration as soon as softening capacity is exhausted.

Pressing and releasing the SET button will advance programming to the next step. Default is "Demand Mode".

4. "96 Hours" is now displayed. Pressing and releasing the CHANGE button will toggle this on and off.

If "96 Hours" is selected, the unit will work no more than 4 days without a regeneration.

Note: If there is iron in your water, select this option.

Pressing and releasing the SET button will advance programming to the next step. Default is for "96 Hours" to be ON.

5. "Gallons X100" is now displayed. Pressing and releasing the CHANGE button will toggle between "Gallons X100" and "Liters X1000". Choosing gallons sets the controller to English units, and choosing liters sets it to metric units. Pressing and releasing the SET button will advance programming to the next step.

6. If "Gallons" was chosen "12" is now displayed. If "Liters" was chosen "24" is displayed. Pressing and releasing the CHANGE button will toggle between "24" and "12". This controls the selection of a 12-hour (AM/PM) or 24-hour clock. If 24-hour, 00=midnight. Default is "12".

Setting The Controller - Continued

7. "Set Time" and "12" is now lit. To set the time, press and hold the CHANGE button to advance the numerical display, and switch from "PM" to "AM" if appropriate. Note: set the time to the nearest hour. Pressing and releasing the SET button will save the time displayed and advance to the next menu. Pressing and releasing the SET button will advance programming to the next step. Default is 12 PM.

8. "Set Reg. Time" and "02" is now displayed. To set the regeneration time, press and release the CHANGE button to advance the numerical display. Pressing and releasing the SET button will save the "regen. time" displayed and put the unit into operation. Default is 2 AM.

PROGRAMMING IS NOW COMPLETE

4 Button Error Descriptions

"E1" Home magnet not found: Cycle power by unplugging the transformer and plugging it back in and it will look for Home again.

"E2" Motor not plugged in: Plug motor in and cycle power. If it is plugged in, then motor wiring or the motor plug is defective.

"E3" Home offset error: Disk didn't start in proper home location. Controller will automatically try to reset itself by finding Home and continuing the regeneration.

"E4" Magnet stuck at Home: Gear teeth aren't engaged, gear stripped, something is jammed in the valve. Cycle the power to reset.

"E5" Memory error: Replace board.

**When calling the HelpLine, please have this guide and the serial number available. From 8 am to 5 pm EST, call 1-800-437-8993.
Your serial number may be found on top of your valve assembly.**

Care, Maintenance and Parts

Figure 11

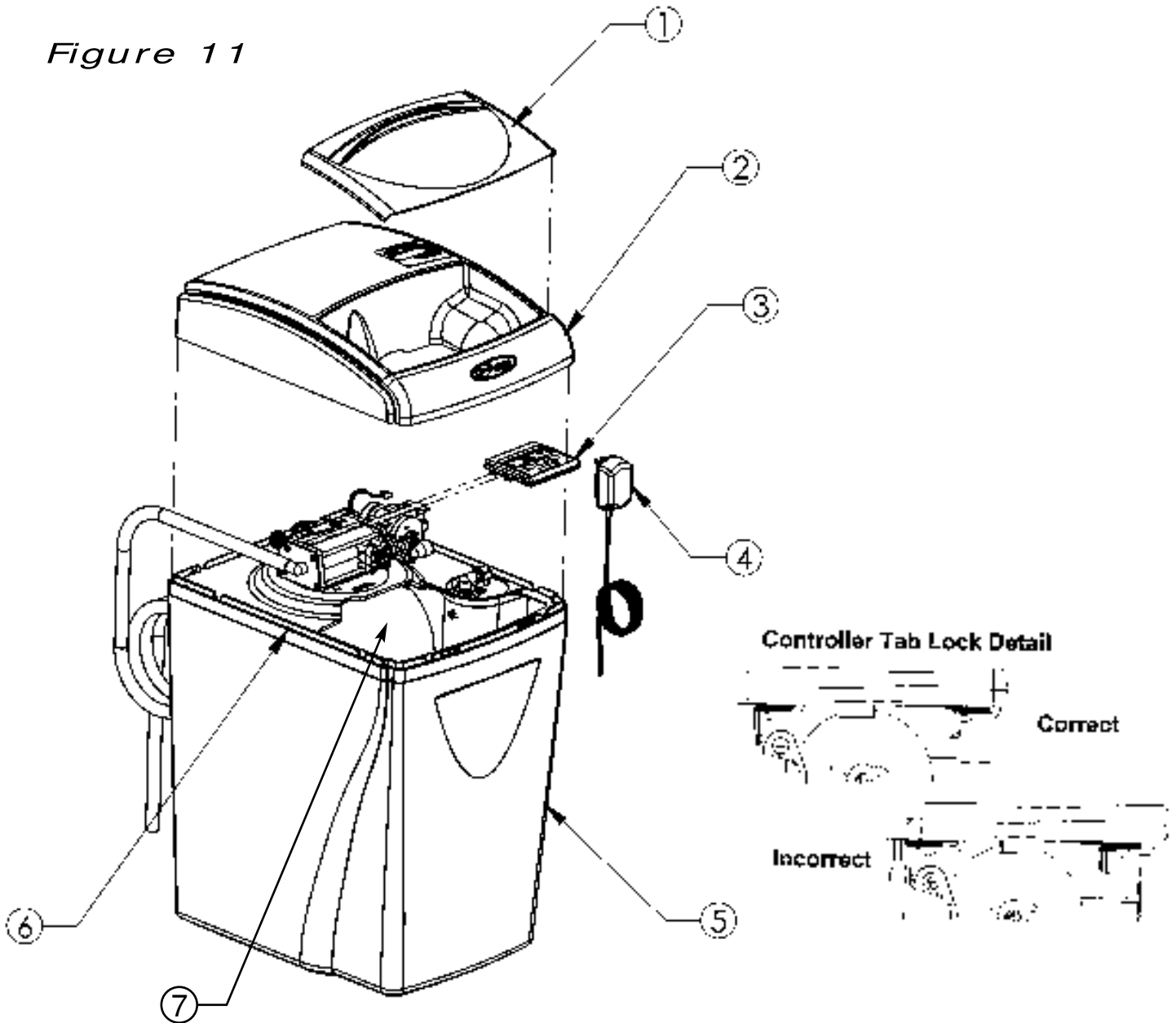

	PART#	DESCRIPTION	QUANTITY
1	54306	Salt Port Lid	1
2	54324	Valve Cover Assembly	1
3	54540-550	Computer Control Assembly	1
	54540-700	Computer Control Assembly	1
	54540-900	Computer Control Assembly	1
4	93245	12V Transformer/Power Cord	1
5	54303	Cabinet. 550 / 700	1
	54309	Cabinet. 900	1
6	54305	Support Panel	1
7	93530-CITY	Media tank, empty, fill plug, 550 only	1
	93530	Media tank, empty, 700 only	1
	95505	Media tank, empty, 900 only	1

Care, Maintenance and Parts

Figure 12 - Cabinet and Assemblies

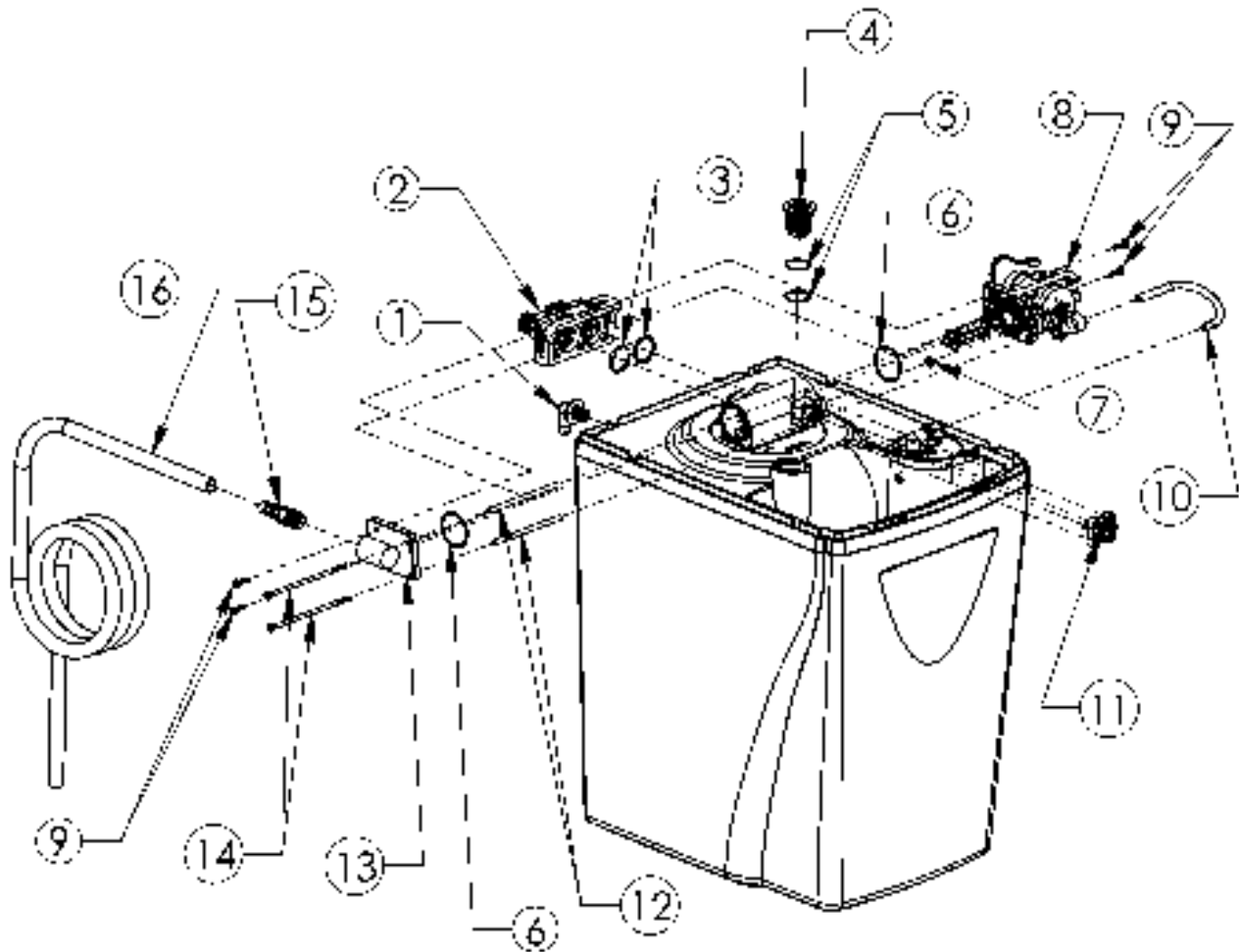

PART#	DESCRIPTION	QUANTITY
1 CO700A	Cabinet Overflow	1
2 54510	I/O Adapter Assembly	1
3 93838	O-Ring	2
4 93281	Fill Plug, Model 550 only	1
5 93272	O-Ring, Model 550 only	2
6 93808	O-Ring	2
7 90828	O-Ring	1
8 95301T-JG	Drive End Cap Assembly	1
9 93870	Screw	4
10 93848	3/8" Brine Line (7")	1
11 93501	Injector Assembly	1
12 93835	Sleeve	2
13 93524	Drain End Cap, Barbed, Model 700 and 900 only, not shown	1
90614-3.0	Drain End Cap Assembly, Model 550 only	1
14 93809	Screw	2
15 V185	Drain Fitting, 1/2" MNT x Barb, Model 550 only	1
16 93842	Drain Line	1

Care, Maintenance and Parts

Figure 13 - Injector Assembly

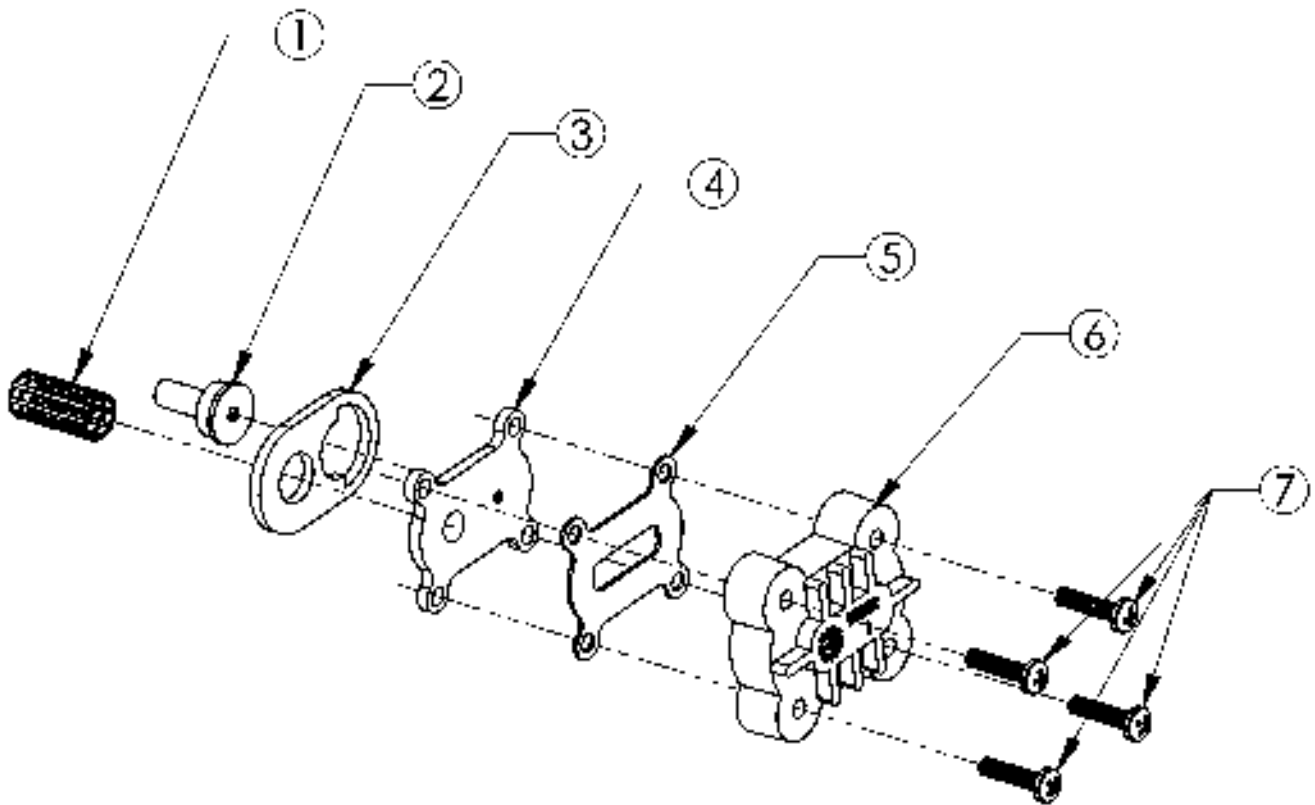

	PART#	DESCRIPTION	QUANTITY
1	93810	Injector Screen	1
2	93223	Injector Throat	1
3	93220	Injector Seal	1
4	93221	Injector Nozzle	1
5	93232	Top Injector Seal (Thin)	1
6	93222	Injector Cap	1
7	90807	Screw	4

93501 includes all of the above.

Care, Maintenance and Parts

Figure 14 - I/O Adapter Assembly

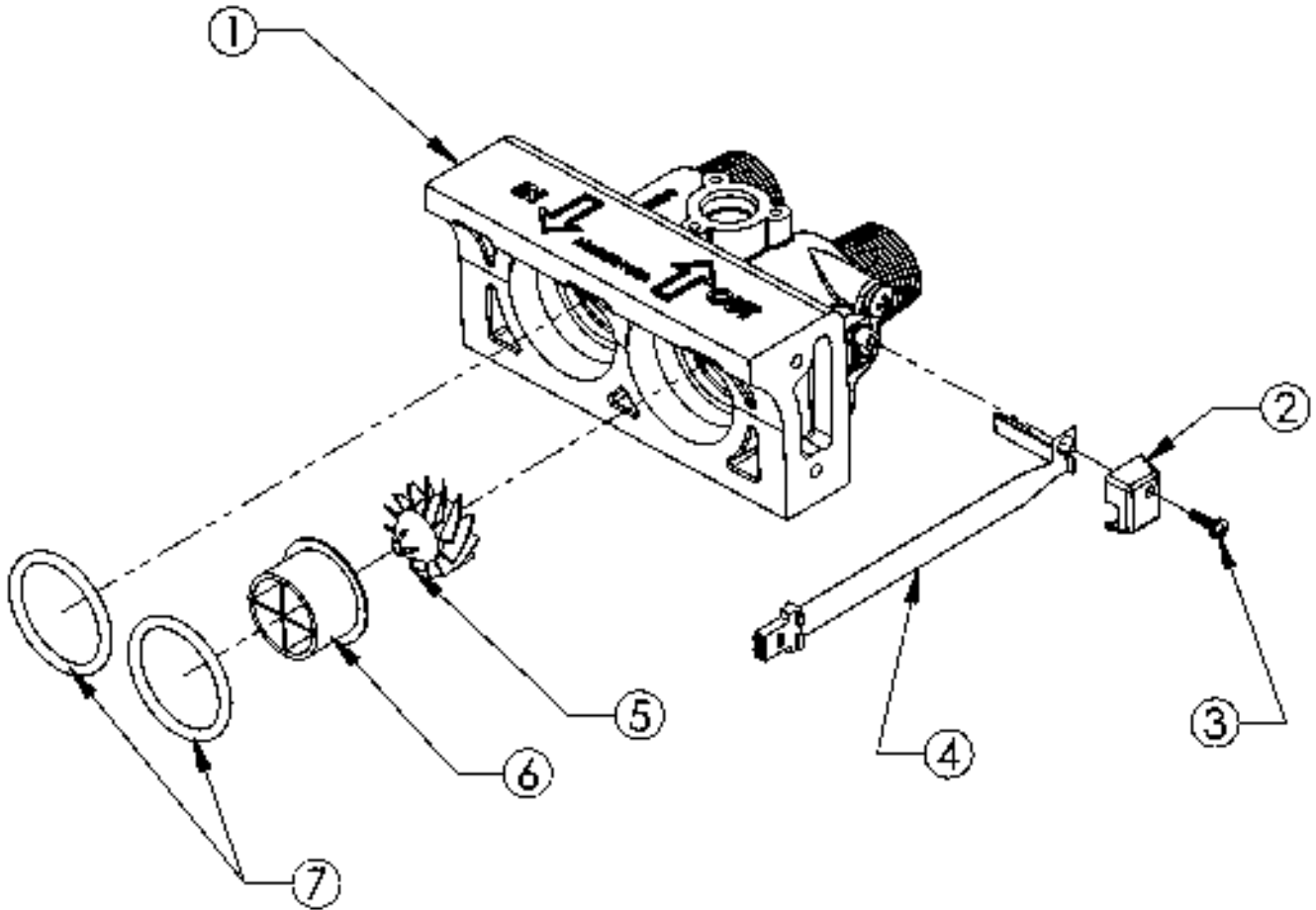

	PART#	DESCRIPTION	QUANTITY
1	54131	3/4" IO Adapter	1
2	90232	Turbine Sensor Cap	1
3	90809	Sensor Cap Screw	1
4	93858	Turbine Sensor Assembly	1
5	90522	Turbine Assembly	1
6	93229	Flow Director	1
7	93838	"O" Ring	2

54510 includes all of the above.

Care, Maintenance and Parts

Figure 15 - Drive End Cap Assembly

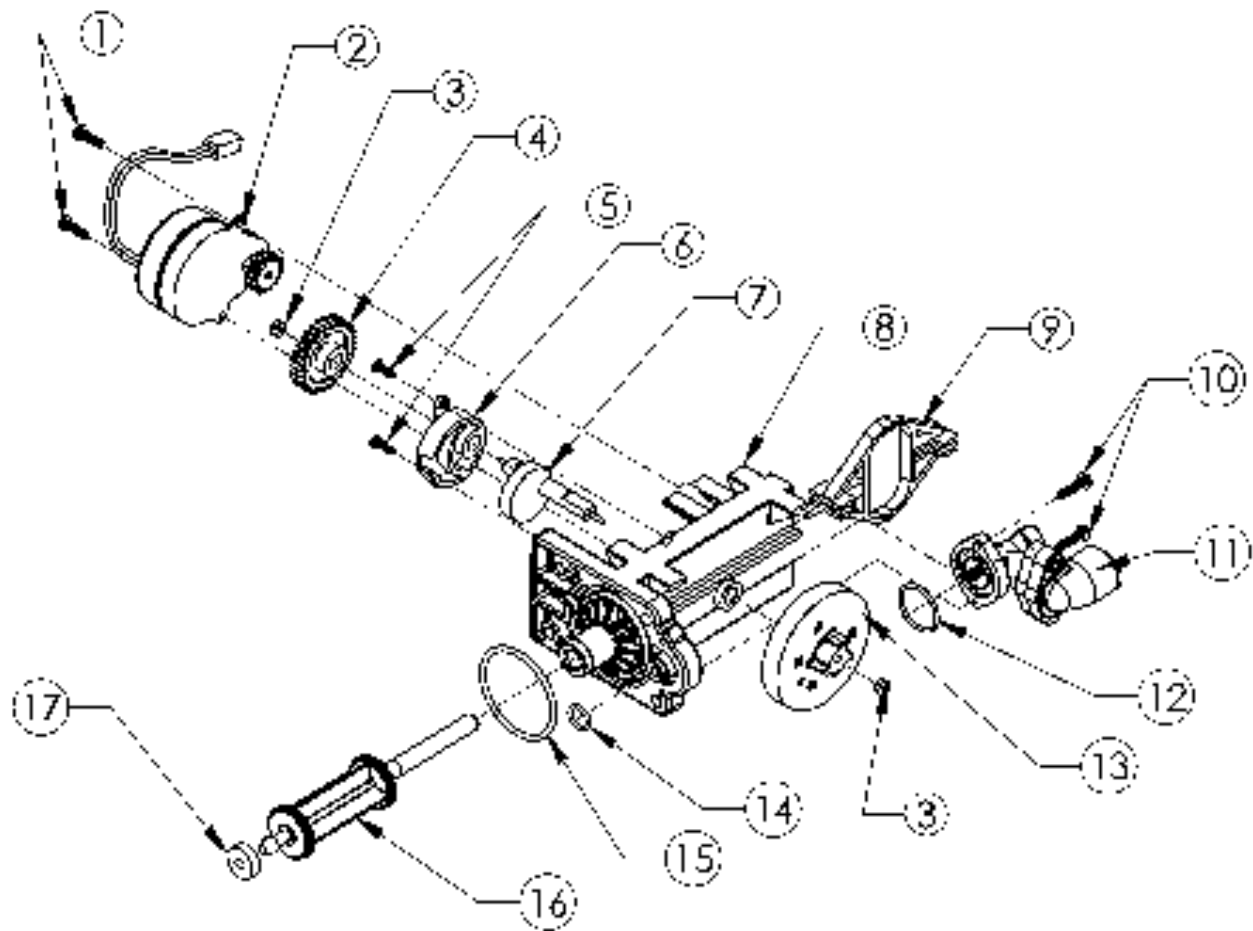

PART#	DESCRIPTION	QUANTITY
1 90802	Screw	2
2 90217	Drive Motor	1
3 93891	1/4" Hex Nut	2
4 93238	Drive Gear	1
5 90809	Screw, Cam Cover	2
6 93219	Piston Slide Cam Cover	1
7 93217	Piston Slide Cam	1
8 93583	Drive End Cap	1
9 93216	Piston Slide	1
10 90818	Screw	2
11 93601-JG	Brine Valve Housing Ass'bly	1
12 90821	O-Ring	1
13 54502	Magnet Disk Assembly	1
14 90828	O-Ring	1
15 93808	O-Ring	1
16 93522-A	Drive Piston Ass'bly	1
17 93839	Drain Gasket	1

Care, Maintenance and Parts

Figure 16 - Brine Valve Housing Assembly

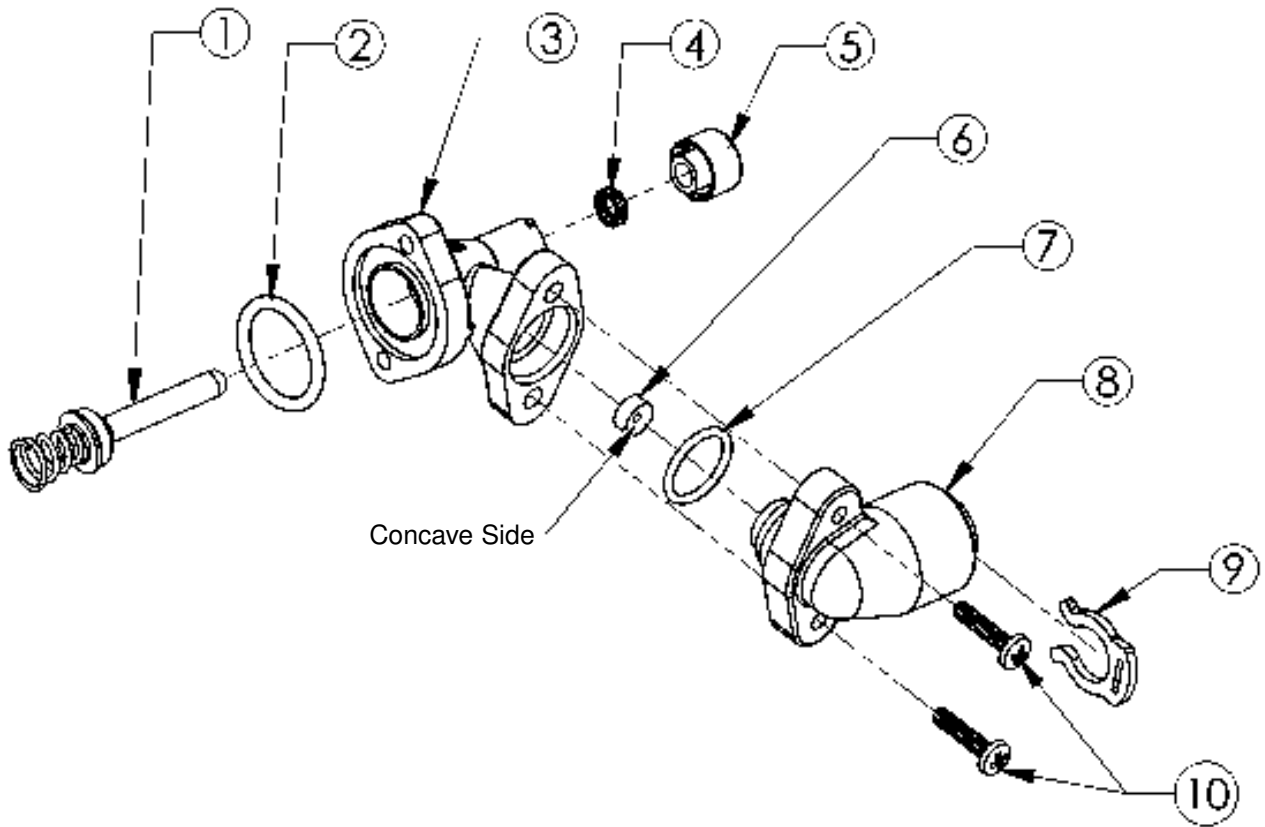

PART#	DESCRIPTION	QUANTITY
1 93620	Piston Assembly (includes O-ring & Spring)	1
2 90821	O-ring	1
3 93260	Housing	1
4 93878	Quad Ring	1
5 93254	Quad Ring Retainer	1
6 90843	.5 pm Flow Control	1
7 93805	O-ring	1
8 93243-JG	Housing Cap Assembly (John Guest)	1
9 200199	3/8" Locking Clip	1
10 90807	Screw	2

93601-JG includes all of the above.

Care, Maintenance and Parts

Figure 17 - Safety Shutoff Assembly

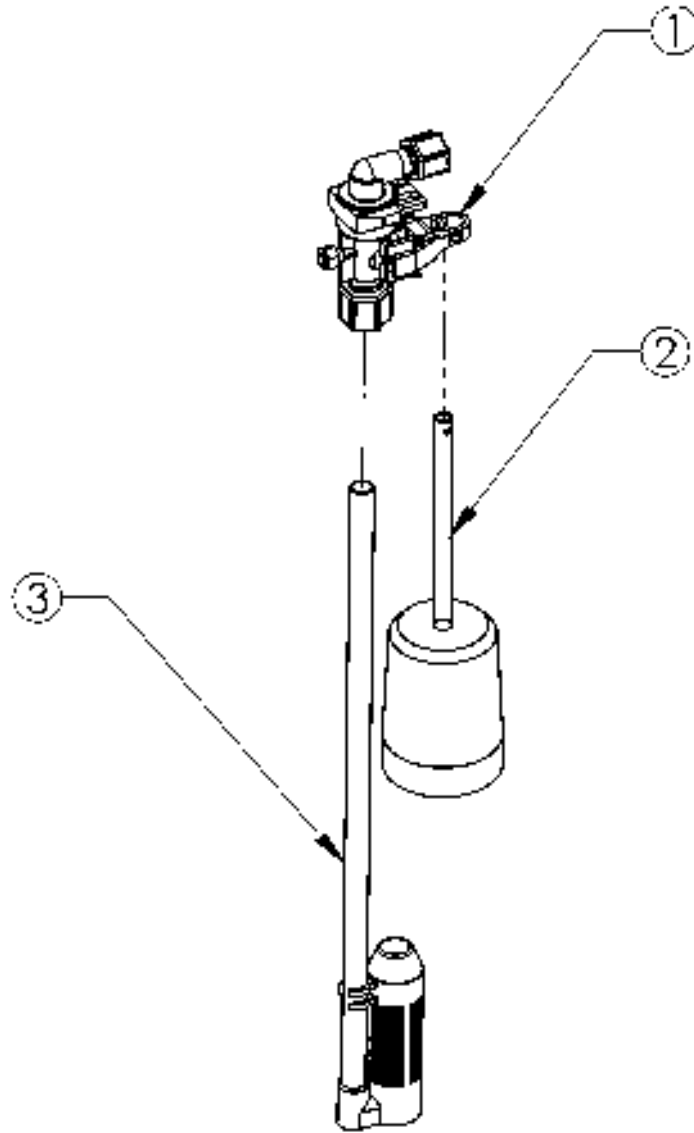

	PART#	DESCRIPTION	QUANTITY
1	54226	Safety Shutoff	1
2	54227	Float	1
3	54228	Air Check, 550 & 700	1
4	54229	Air Check, 900	1

Care, Maintenance and Parts

Figure 18 - Brine Valve Elbow Assembly

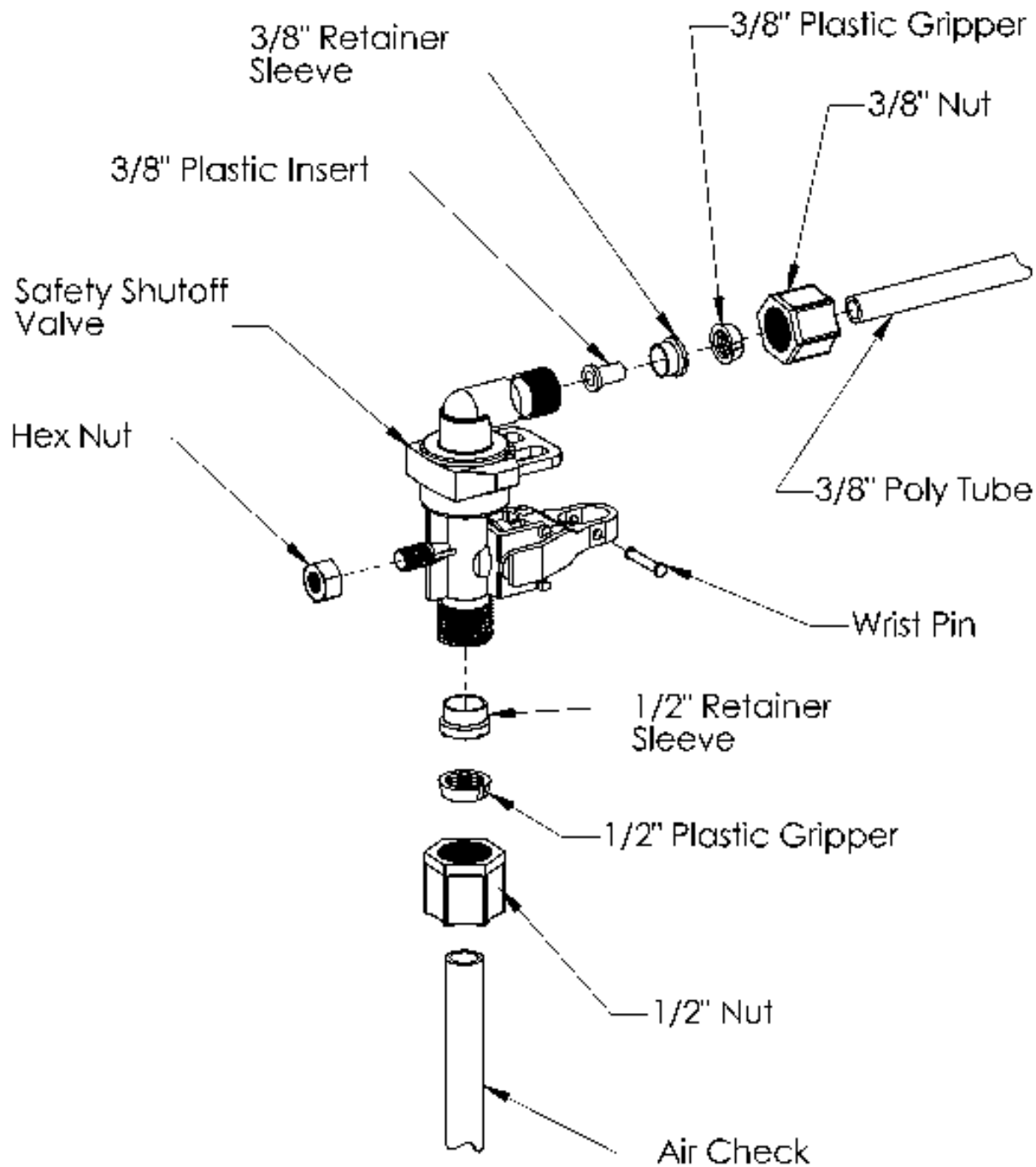

Care, Maintenance and Parts

Figure 19 - Bottom Fill Plug Assembly

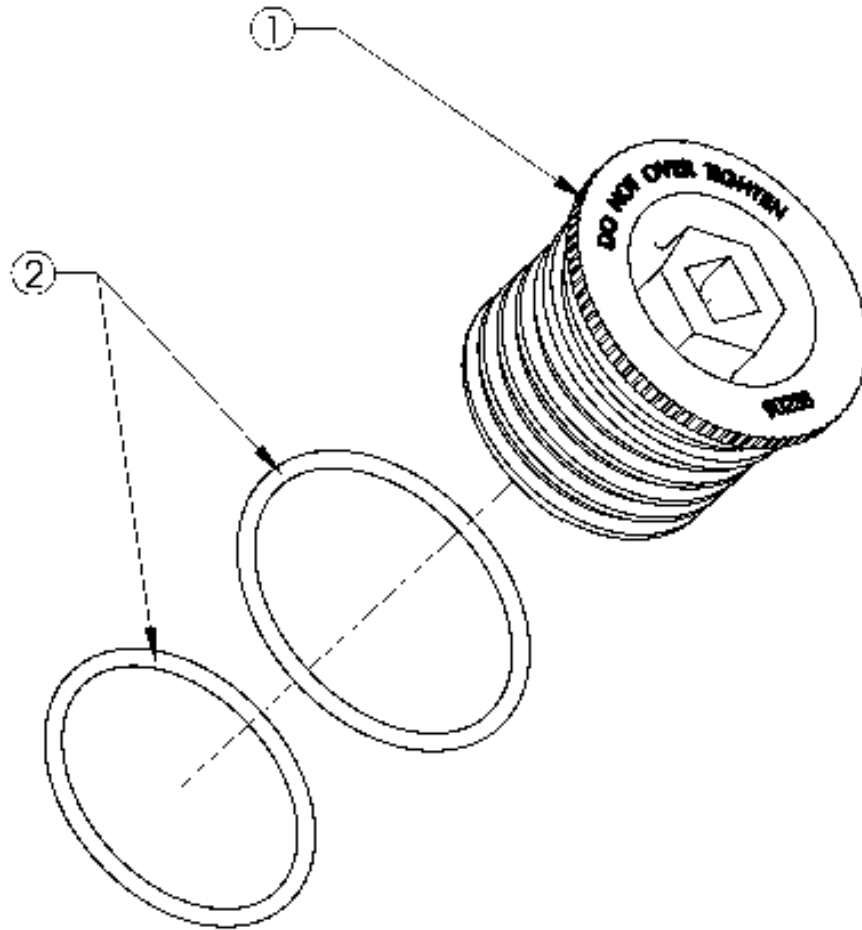

	PART#	DESCRIPTION	QUANTITY
1	90238	Fill Plug	1
2	90819	O-ring	2

Specifications/Capacity Chart

MODEL #	700	900	550
Maximum compensated hardness (grains)	70	90	25
Maximum ferrous iron reduction	10 ppm	10 ppm	0
Minimum pH	7	7	7
Media type and amounts	Power Clean Filter Media Super Fine Mesh Resin - .7 cu. ft.	Power Clean Filter Media Super Fine Mesh Resin - 1 cu. ft.	Redox Media - 4 lbs Activated Carbon - .15 cu.ft Super Fine Mesh Resin - .5 cu. ft.
Salt usage (lbs.) / Capacity (HC - High Capacity)	6.5 / 17,800	7.5 / 27,000	5.0 / 11,500
Salt usage (lbs.) / Capacity (HE - High Efficiency)	2.5 / 10,500	6.0 / 24,000	1.25 / 5,000
Maximum water temperature	120°F	120°F	120°F
Mineral tank size	10.5 X 14" I.D.	10.5 X 21" I.D.	10.5 X 14" I.D.
Peak flow rate / psi drop	16 gpm/15	10 gpm/14.5	10 gpm/15
Pressure drop @ service flow rate of 4 gpm	3.2	4.0	3.2
Maximum flow rate to drain during regeneration (backwash gpm)	2.0	2.0	3.0
Water Pressure (minimum-maximum psi)	20 / 120	20 / 120	20 / 120
Minimum water flow required (gpm)	5	5	5
Maximum Chlorine (ppm)	1	1	2
Controller type	4 Button	4 Button	4 Button
Regeneration time (minutes) (HC - High Capacity)	33	48	27
Regeneration time (minutes) (HE - High Efficiency)	18	38	9
Water used/regeneration (gallons) (HC - High Capacity)	25	33	25
Water used/regeneration (gallons) (HE - High Efficiency)	16	27	15
Frequency of regeneration (days)	Demand	Demand	Demand
Salt Storage	120 lbs.	160 lbs.	120 lbs.
Height (in.)	25.75"	30.75"	25.75"
Footprint (in.)	14.75" X 18.75"	14.75" X 18.75"	14.75" X 18.75"
Electrical Rating	12VAC, 1 phase60 Hz	12VAC, 1 phase60 Hz	12VAC, 1 phase60 Hz
Plumbing Connections	3/4" MNPT	3/4" MNPT	3/4" MNPT
Shipping Weight - Approximate (lbs.)	85 lbs	105 lbs	85 lbs

When calling the HelpLine, please have this guide and the serial number available. From 8 am to 5 pm EST, call 1-800-437-8993.
Your serial number may be found on top of your valve assembly.

Troubleshooting

<i>Problem</i>	<i>Cause</i>	<i>Solution</i>
No soft water after regeneration.	No salt in brine cabinet.	Add salt (refer to "Regenerate" Page 13)
	Sediment in brine tank has plugged the brine line and air check.	Remove air check draw tube and flush with clean water. Clean injector assembly. Clean any sediment from brine cabinet.
	Drain line is pinched, frozen or restricted.	Straighten, thaw or unclog the drain line.
	Clogged injector assembly (page 18).	Remove injector cap and clean nozzle and throat with a wooden toothpick. Clean screen and replace throat if removed.
	Salt bridge has formed.	High humidity or the wrong kind of salt can create a salt bridge. This is a crust that forms an empty space between the water and salt. To test, use a blunt object like a broom handle. Push the handle into the salt to dislodge the salt bridge.
No soft water.	The plumbing bypass valve is in the the bypass position (page 7).	Place bypass valve in the service position.
	Unit is plumbed backwards.	Check that unit is plumbed correctly.
	Extended power outage.	Reset hardness (refer to "Regenerate" Page 13).
	Water hardness has increased.	Reset water and reset hardness.
	Not metering water.	Check waterMizer light. Light should flash with water usage. If no light, see below.
waterMizer light does not turn when water is flowing.	The plumbing bypass valve is in the the bypass position (page 7).	Place bypass valve in the service position.
	Unit is plumbed backwards.	Check that unit is plumbed correctly.
	Sensor not receiving signal from magnet on turbine (page 19).	Remove sensor from IO housing. Test by placing magnet on the sensor chip. If light turns, clean or replace turbine. If no light, replace sensor.
waterMizer light turns when water is not being used.	There is a leak in your household plumbing appliance.	Repair the leak.
waterMizer light turns steadily.	Turbine stopped over sensor.	Run water. Verify flashing light.
Read-out lights do not glow.	Electric cord is unplugged.	Plug in transformer.
	No electric power at outlet.	Check power source. Make sure outlet is not controlled by a switch.
	Defective transformer (fig. 8).	Test with volt meter for 12 VAC at control. If 0 VAC, replace transformer.

Troubleshooting

<i>Problem</i>	<i>Cause</i>	<i>Solution</i>
Read-out lights do not glow.	Defective circuit board (fig. 9).	With 12 VAC present at controller, replace circuit board.
Unit stays in regeneration. Cycle numbers remain flashing.	Computer control not attached properly.	Make sure computer control is pushed all the way onto drive end cap.
	Foreign object in valve body.	Remove foreign objects from valve body.
	Broken valve assembly. Motor running. Magnet disc not turning (page 20).	Repair drive end cap.
Excess water in brine tank. Should be approx. 6 - 8" with salt for Models 700 and 550, and 8-10" for Model 900.	Restricted, frozen or pinched drain line.	Remove restriction, thaw or straighten drain line.
	Plugged brine line, brine line flow control or air check (page 21, 22).	Clean flow control, air check and brine line. Clean any sediment from brine cabinet.
	Plugged injector assembly (page 18).	Clean or replace injector. Replace throat if removed.
	Sticking brine refill valve.	Remove brine valve. Lubricate piston with silicone grease and reassemble.
Not regenerating in proper sequence.	Magnet disc defective.	Replace magnet disc.
	Defective position sensor.	Replace control.
Salty water.	Plugged Injector.	Clean injector screen, nozzle and throat. See figure 13 page 18.
	Low water pressure.	Maintain min. pressure of 20 psi. See specifications page 25.
	Drain line or flow control restricted.	Remove restrictions.
	Brine line restricted or crimped.	Remove restrictions, replace if crimped.
	Excessive amount of water in brine cabinet.	Verify correct water level relative to salt setting. Check lines for loose connections.
	Intermittent pressure drop from feed source.	Verify adequate pressure and volume of water supply. See specifications page 25.

When calling the HelpLine, please have this guide and the serial number available. From 8 am to 5 pm EST, call 1-800-437-8993.
Your serial number may be found on top of your valve assembly.

Limited Warranty

To Whom Warranty is Extended

This warranty is issued to the original owner at the original location site and is not transferable to other sites or to subsequent owners of the appliance.

TO PLACE THE EQUIPMENT UNDER WARRANTY, THE WARRANTY REGISTRATION CARD MUST BE COMPLETED AND RETURNED BY THE ORIGINAL OWNER TO **WaterBoss®** WITHIN 30 DAYS OF INSTALLATION.

Coverage

This limited warranty covers the **WaterBoss®** appliances delivered to the original owner at the original location when the appliance is purchased for personal, family, or household use. It is intended to cover defects occurring in workmanship or materials or both.

Warrantor's Performance and Length of Limited warranty - **WaterBoss®** warrants that upon receipt from the original owner of any mechanical or electronic part which is found to be defective in materials or workmanship, **WaterBoss®** will repair or replace the defective item for 3 years from date of original installation.

WaterBoss® further warrants that upon receipt from the original owner of any **WaterBoss®** media tank / valve body, brine cabinet, found to be defective in material or workmanship, **WaterBoss®** will repair or replace the defective item for 10 years from date of original installation.

All defective parts must be returned, along with the equipment serial number and date of original installation, to **WaterBoss®** PREPAID, and replacement parts will be returned by **WaterBoss®** to the original owner FREIGHT COLLECT.

FURTHER EXCLUSIONS AND LIMITATIONS ON WARRANTY

THERE ARE NO WARRANTIES OTHER THAN THOSE DESCRIBED IN THIS WARRANTY INSTRUMENT.

This warranty does not cover any service call or labor costs incurred with respect to the removal and replacement of any defective part or parts. **WaterBoss®** will not be liable for, nor will it pay service call or labor charges incurred or expended with respect to this warranty.

In the event the water supply being processed through this product contains bacterial iron, algae, sulphur, tannins, organic matter or other unusual substances, then, unless the appliance is represented as being capable of handling these substances in the product specifications, other special treatment of the water supply must be used to remove these substances before they enter this product. Otherwise, **WaterBoss®** shall have no obligations under this warranty.

This warranty does not cover damage to a part or parts of the appliance from causes such as fire, accidents, freezing, or unreasonable use, abuse or neglect by the owner.

This warranty does not cover damage to a part or parts of the appliance resulting from improper installation. All plumbing and electrical connections should be made in accordance with all local codes and the installation instructions provided with the appliance. The warranty does not cover damage resulting from use with inadequate or defective plumbing; inadequate or defective water supply or pressure; inadequate or defective house wiring; improper voltage, electrical service, or electrical connections; or violation of applicable building, plumbing, or electrical codes laws, ordinances or regulations.

THIS WARRANTY DOES NOT COVER INCIDENTAL,

CONSEQUENTIAL OR SECONDARY DAMAGES.

ANY IMPLIED WARRANTIES ON THE PRODUCT DESCRIBED IN THIS WARRANTY WILL NOT BE EFFECTIVE AFTER THE EXPIRATION OF THIS WARRANTY.

Some states do not allow limitations on how long an implied warranty lasts or the exclusion or limitation of incidental or consequential damages, so the above limitations and exclusion may not apply to you. This warranty gives you specific legal rights and you may also have other rights which vary from state to state.

Claims Procedures

Any defects covered by this warranty should be promptly reported to: **WaterBoss®**
4343 South Hamilton Road,
Groveport, Ohio 43125

In writing about the defects, please provide the original owner's name, telephone number and original address, serial number and model number of the product, and date of purchase. **WaterBoss®** reserves the right to replace defective parts with exact duplicates or their equivalent.

For Owner's Reference

Model No. _____

Equipment Serial No. _____

Installation Date _____

Installer's Signature _____

WaterBoss® will not accept any returns after 6 months from date of purchase.

Call: 1-800-437-8993
For Return Information

Notes

**When calling the HelpLine, please have this guide and the serial number available. From 8 am to 5 pm EST, call 1-800-437-8993.
Your serial number may be found on top of your valve assembly.**

WaterBoss[®] water softener

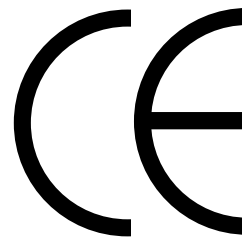

In Business Since 1956

©1998 **WaterBoss**[®] P.O. Box 298, Groveport, OH 43125

LITHO USA

Form #93966

Version 4

RV0403WAL24M