

# **Autotrol® Performa™ Filter Valve Series**

---

**440i Control**

**940F Control**

**960F Control**

**Water Conditioning Control System**

**Installation, Operation and Maintenance Manual**



---

---

## Table of Contents

Installation . . . . .	3
Location Selection	
Water Line Connection	
Drain Line Connection	
Placing Conditioner into Operation . . . . .	4
Electrical Connection	
400 Series Control Settings . . . . .	5
440i	
Programming	
900 ProSeries Control Settings . . . . .	5
940F	
Programming	
Manual Regeneration	
960F	
Programming	
Level I Parameters	
Level II Parameters	
Regeneration . . . . .	11
Manual Regeneration	
Automatic Regeneration	
Removing the Valve Assembly or Servicing . . . . .	12
Removing 440i Control for Servicing . . . . .	12
Removing the 940F and 960F Controls for Servicing . . . . .	13
Preventative Maintenance . . . . .	14
Water Meter Maintenance	
Specifications . . . . .	15
Control Valving Identification . . . . .	17
Valve Disc Principle of Operation . . . . .	17
Flow Diagrams . . . . .	17
Replacement Parts . . . . .	19
Troubleshooting . . . . .	22

## Installation

All plumbing and electrical connections must conform to local codes.

Inspect unit carefully for carrier shortage or shipping damage.

## Location Selection

1. The distance between the unit and a drain should be as short as possible.
2. If it is likely that supplementary water treatment equipment will be required, make certain adequate additional space is available.
3. Do not install any unit closer to a water heater than a total run of 10 feet (3 m) of piping between the outlet of the conditioner and the inlet to the heater. Water heaters can sometimes overheat to the extent they will transmit heat back down the cold pipe into the unit control valve.

Hot water can severely damage the conditioner. A 10-foot (3-m) total pipe run, including bends, elbows, etc., is a reasonable distance to help prevent this possibility. A positive way to prevent hot water flowing from heat source to the conditioner, in the event of a negative pressure situation, is to install a check valve in the soft water piping from the conditioner. **If a check valve is installed, make certain the water heating unit is equipped with a property rated temperature and pressure safety relief valve. Also, be certain that local codes are not violated.**

4. Do not locate unit where it or its connections (including the drain) will ever be subjected to room temperatures under 34°F (1°C) or over 120°F (49°C).
5. Do not install unit near acid or acid fumes.

## Water Line Connection

The installation of a bypass valve system is recommended to provide for occasions when the water conditioner must be bypassed for hard water or for servicing.

The most common bypass systems are the Autotrol Series 1265 bypass valve (Figure 1) and plumbed-in globe valves (Figure 2). Though both are similar in function, the Autotrol Series 1265 bypass offers simplicity and ease of operation.

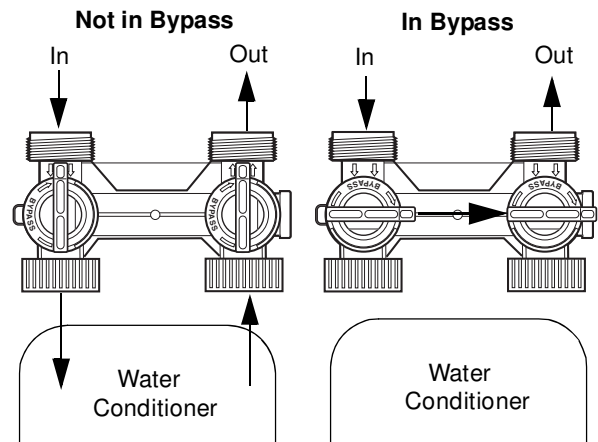

Figure 1

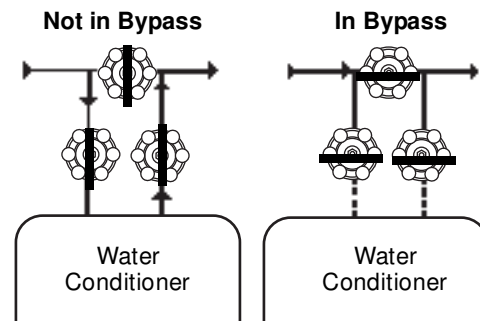

Figure 2

## Drain Line Connection

**Note:** Standard commercial practices are expressed here. Local codes may require changes to the following suggestions.

1. Ideally located, the unit will be above and not more than 20 feet (6.1 m) from the drain. For such installations, using an appropriate adapter fitting, connect 1/2-inch (1.3-cm) plastic tubing to the drain line connection of the control valve.
2. If the backwash flow rate exceeds 5 gpm (22.7 Lpm) or if the unit is located more than 20 feet (6.1 m) from drain, use 3/4 -inch (1.9-cm) tubing for runs up to 40 feet (12.2 m). Also, purchase appropriate fitting to connect the 3/4-inch tubing to the 3/4-inch NPT drain connection.
3. If the unit is located where the drain line must be elevated, you may elevate the line up to 6 feet (1.8 m) providing the run does not exceed 15 feet (4.6 m) and water pressure at conditioner is not less than 40 psi (2.76 bar). You may elevate an additional 2 feet (61 cm) for each additional 10 psi (0.69 bar).
4. Where the drain line is elevated but empties into a drain below the level of the control valve, form a

7-inch (18-cm) loop at the far end of the line so that the bottom of the loop is level with the drain line connection. This will provide an adequate siphon trap.

5. Where the drain empties into an overhead sewer line, a sink-type trap must be used.

**IMPORTANT:** Never insert drain line into a drain, sewer line or trap. Always allow an air gap between the drain line and the wastewater to prevent the possibility of sewage being back-siphoned into the conditioner.

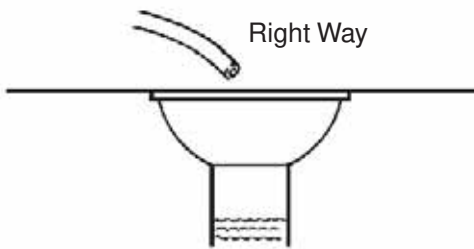

Figure 3

**Note:** Standard commercial practices have been expressed here. Local codes may require changes to these suggestions.

## Placing Conditioner into Operation

After all previous steps have been completed the unit is ready to be placed into operation. Follow these steps carefully.

1. Remove control valve cover.

**Note:** The following steps will require turning the indicator knob (Figure 4 and Figure 5) or the cycle indicator (Figure 7) to various positions. Manually rotate the camshaft **COUNTERCLOCKWISE** only until indicator knob and cycle indicator points to desired position. (See manual regeneration sections for each control's manual operation.)

2. Rotate indicator knob or cycle indicator **COUNTERCLOCKWISE** until it points directly to the word **BACKWASH**.
3. Fill media tank with water.
  - a. With water supply off, place the bypass valve(s) into the "service" position.
  - b. Open water supply valve very slowly to approximately the 1/4 open position.

**IMPORTANT:** If opened too rapidly or too far, media may be lost. In the 1/4 open position, you should hear air escaping slowly from the drain line.

- c. When all of the air has been purged from the tank (water begins to flow steadily from the drain), open the main supply valve all the way.
  - d. Allow water to run to drain until clear.
  - e. Turn off water supply and let the unit stand for about five minutes. This will allow all trapped air to escape from the tank.
4. Place the conditioner into operation.
    - a. Advance the indicator knob or cycle indicator **COUNTERCLOCKWISE** to the **SERVICE** position and run water from a nearby faucet until the water is clear.

## Electrical Connection

**100 VAC, 115 VAC, and 230 VAC** units: Remove twist tie from the power cord and extend cord to its full length. Make sure the power source matches the rating printed on the control. Be certain a wall switch does not control the outlet.

**12 VAC:** Connect the plug of the transformer (supplied) secondary cable to the mating socket at the rear or bottom of the timer housing. Be certain the transformer is secure and is plugged into a power source of correct voltage that is not controlled by a wall switch.

## 400 Series Control Settings

### 440i Control

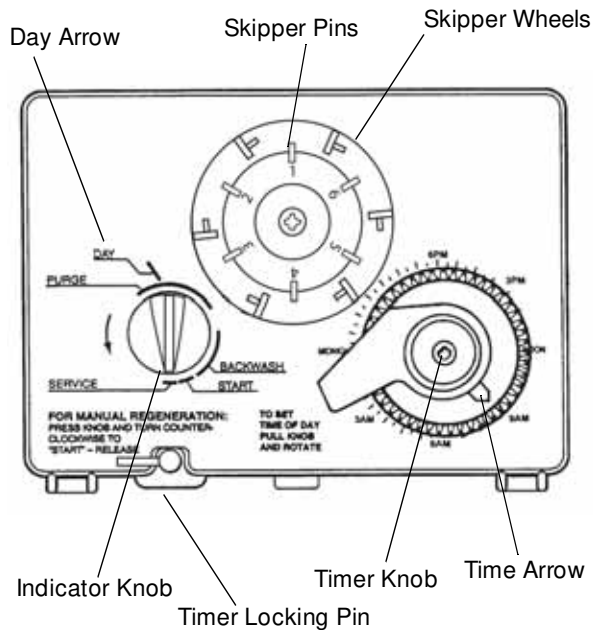

Figure 4

### Programming

1. Set days of regeneration on skipper wheel (Figure 4).
  - Pull all skipper pins outward (away from control).
  - Rotate skipper wheel until day arrow points to current day or number 1.
  - Depress skipper pin(s) at day(s) for which regeneration is desired.
2. Set the time of day.
  - Grasp timer knob and pull outward.
  - Rotate in either direction until the timer arrow points to the actual time of day.
  - Release timer knob.

**Note:** with the time of day properly set, the conditioner will regenerate at about 2:30 a.m. If you prefer to have the unit regenerate at an earlier or later time, simply set current time-of-day accordingly (e.g., to have the unit regenerate at 4:30 a.m. - two hours later - set the clock two hours earlier than the actual time of day.)

**Note:** The timer locking pin should always be horizontal (Figure 4) during operation.

### Guest Cycle

When abnormally high water usage exhausts your water conditioner's capacity ahead of schedule, an

extra regeneration can be achieved. Depress the indicator knob on the 440i (Figure 4) with a wide-blade screwdriver and turn **COUNTERCLOCKWISE** to **START** to initiate a regeneration. It will take a few minutes for regeneration to start. A normal regeneration will take approximately two hours.

### Manual Regeneration

Electricity is used only to run the control and to rotate the camshaft. All other functions are operated by water pressure. Therefore, in the event of a power outage, all the regeneration positions may be dialed manually by depressing the indicator knob and turning **COUNTERCLOCKWISE** (Figure 4). The following cycle times should be used for proper regeneration:

**BACKWASH** - 20 minutes

**FAST RINSE** - 10 minutes

## 900 ProSeries Control Settings

### 940F Control

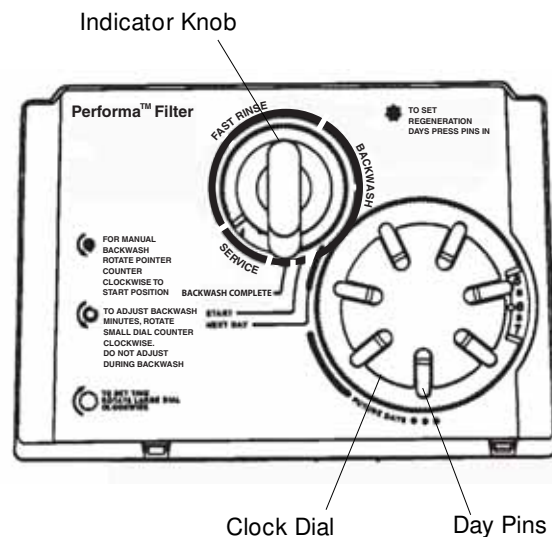

Figure 5

### Programming

1. Set days of regeneration (Figure 5).
  - Pull all day pins outward (away from control).
  - Depress day pin(s) for which regeneration is desired.

**Note:** The **NEXT DAY** day pin is noted on the timer face. Depressing this pin will insure a regeneration the next day at approximately 2:00 a.m. Since the calendar cap progresses **CLOCKWISE**, depressing the day pin immediately **COUNTERCLOCKWISE** will insure a regeneration the following day at 2:00 a.m. This progression is noted on the timer face as "FUTURE DAYS".

2. Set the time of day.

- Rotate Clock Dial **CLOCKWISE** until the pointer is directed at the current time.

**Note:** With the time of day properly set, the conditioner will regenerate at about 2:00 a.m. If you prefer to have the unit regenerate at an earlier or later time, simply set the current time-of-day accordingly (e.g., to have the unit **REGENERATE** at 4:00 a.m. - two hours later - set the clock two hours earlier than the actual current time).

**Note:** Do not rotate the Calendar Cap by hand; the clock dial indexes it daily. To manually index the Calendar Cap, rotate the Clock Dial **CLOCKWISE** one complete turn for every day to be indexed.

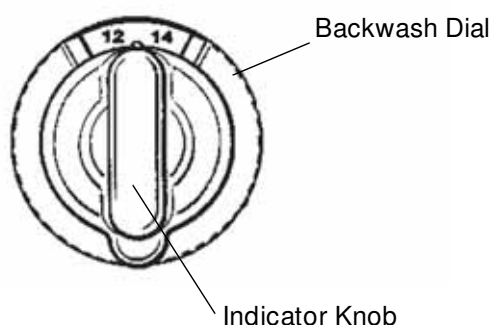

Figure 6

### How to Adjust the Backwash Time

With the indicator knob in the **BACKWASH COMPLETE** position (Figure 6), rotate the Backwash Dial **COUNTERCLOCKWISE** at least one full turn to cancel the previous setting. A light clicking will be replaced by a heavier clicking when the previous setting is cancelled. Then, rotate the Backwash Dial to the desired backwash time. The numbers are minutes of backwash per regeneration.

### Manual Regeneration

Electricity is used only to run the control and to rotate the camshaft. All other functions are operated by water pressure. Therefore, in the event of a power outage, all regeneration positions may be dialed manually. Grasp the indicator knob and turn **COUNTERCLOCKWISE** to each regeneration cycle (rotation is much easier if you grasp the camshaft with your free hand and turn it at the same time). The following cycle times should be used for proper regeneration.

**BACKWASH** - 20 minutes

**FAST RINSE** - 10 minutes

## 960F Control

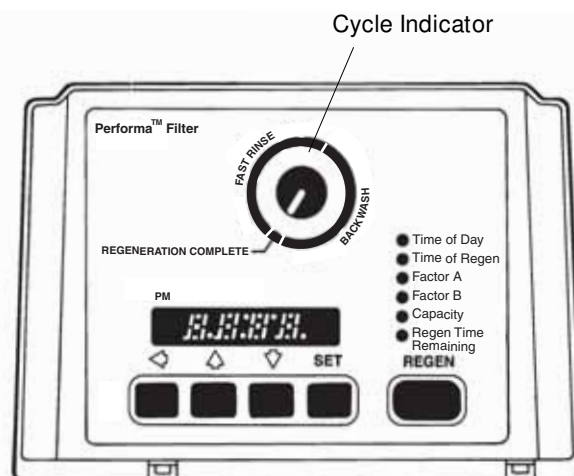

Figure 7

### Programming

This section covers all aspects of programming the control. The control is shipped from the factory with default values for most parameters. These default values will result in a system capacity of 100 gallons (1 cubic meter). While the control may operate with these values, the following parameters must be changed to meet the actual operating conditions:

Refill Controller Value, Brine Draw Rate, and Slow Rinse Time parameters are not required for 960F operation, but should be adjusted as instructed to achieve the shortest possible backwash cycle time.

Note that some parameters have a single unit of measure option. Other parameters have dual units such as Capacity which can be entered in gallons or cubic meters. To select which units are active, look for a comment in the NOTES column of Tables 1 and 2. It will reference another parameter that selects which units are active. For example, parameter P12 (Table 2) selects U.S. units if it is set to "0" and metric if it is set to "1".

---

---

## Level I Parameters (Table 1)

Level I parameters are identified as those that have an LED indicator on the front panel. The green indicator illuminates next to the name of the active control settings. The end user has access to all of these parameters. In general, pressing the down arrow (↓) button displays the Level I Parameters in the following order:

- Time of Day
- Time of Regen
- Factor A
- Factor B
- Capacity

If you continue to press the down arrow (↓) button, the parameters start over with Time of Day. Pressing the up arrow (↑) button displays the parameters in reverse order. Refer to Table 1 for a description of these parameters and the available ranges for each parameter.

Press the **SET** button and the far right digit of the display starts flashing. If you want to change this number, press the up arrow (↑) button to increase the number or the down arrow (↓) button to decrease the number. To skip the number without changing, press the left arrow (←) button. When you reach the far left digit, pressing the left arrow (←) button will return you to the far right digit.

**Note:** If you press and hold either the up arrow (↑) button or the down arrow (↓) button for more than one second, the flashing number will increment or decrement at the rate of 10 counts per second.

When the number is correct, press the left arrow (←) button. The far right digit stops flashing and the next digit to the left starts flashing. **You can only change the flashing number.** Continue changing numbers until you reach the desired setting. Press the **SET** button. The numbers stop flashing and the control accepts the new setting. After approximately 30 seconds, the control starts alternating the display between Time of Day and Capacity.

**Note:** If the new setting is not accepted because it was outside the allowable range, the old value will be displayed.

### Time of Day

Press the **SET** button. The display will show the Time of Day with the minutes digit blinking. If you want to change this number, press the up arrow (↑) button to increase the number or the down arrow (↓) button to decrease the number. To skip the number without changing, press the left arrow (←) button. The first number stops flashing and the next number starts

flashing. **You can only change the flashing number.** When you have reached the far left digit, pressing the left arrow (←) button returns you to the far right digit. Continue changing numbers until you reach the desired setting. Press the **SET** button again to enter the value.

### Time of Backwash

The next value displayed is the Time of Backwash. It is similar to Time of Day programming. It has a default value of 2:00 a.m. If 2:00 a.m. is acceptable, press the down arrow (↓) button. If this is not acceptable, press the **SET** button and change the numbers. Press the **SET** button again to enter the value.

### Factor A

Factor A is the next value displayed. The 960F control uses this value to calculate the system capacity. **Factor A must be set to 10 (100 for metric units) for the 960F control to accurately calculate system capacity.** The default value is 10 (100 for metric units). If the Factor A setting is not correct, press the **SET** button and change the value. Press the **SET** button again to enter the new value.

### Factor B

Factor B is the next value displayed. This value is used by the control to calculate the pause for the refill cycle. Because the refill cycle is not required for 960F operation, Factor B should be set to 0.2 (0.1 for metric units). This is the minimum setting and will cause the control to skip the refill cycle, thereby shortening the backwash cycle time. The default value for Factor B is 0.2 (0.1 for metric units). To change Factor B, press the **SET** button and change to the correct value. Press the **SET** button again to enter the new value.

### Capacity

Capacity is the next value displayed and is used by the 960F control in combination with Factor A to determine the capacity of the filter. The Capacity value should be set to the actual capacity of the filter expressed as gallons/100 (cubic meters/10 for metric units).

**Example:** If the actual filter capacity is 950 gallons, enter 9.5 for the Capacity setting. The default value for Capacity is 1.0 (0.1 for metric units). To change the Capacity setting, press the **SET** button and adjust the correct value. Press the **SET** button again to enter the new value.

At this time, all of the Level I parameters are programmed. The display will alternate between the Time of Day and Capacity if no keys are pressed for 30 seconds. The Capacity value displayed is the volume remaining in gallons (cubic meters for metric) before a backwash is needed.

**Note:** The 960F control uses Factor A and Capacity settings to calculate the actual system capacity. If the actual system capacity is in excess of 9999 gallons (99.99 cubic meters) the control will display 9999 (99.99) until the water usage has dropped the remaining capacity below that number. When water is

flowing through the system, the colon in the Time of Day display will blink.

To complete the initial programming of the 960F, proceed to the **Level II Parameters**.

**Table 1 - Level I Programming Parameters**

Parameter		Range of Values	Minimum Increments	Default	Units of Measure	Notes
Name	Description					
P1	Time of day AM or PM	1:00 to 12:59 00:00 to 23:59	1	None	Hour: minute	Range depends on value selected for P13. Enter the current time.
P2	Time of day of backwash	1:00 to 12:59 AM or PM 00:00 to 23:59	1	2:00 AM	Hour: minute	Range depends on value selected for P13. Skip this parameter to accept the default or enter a new time.
P3	Factor A	3 to 250 30 to 2500	1 10	10 100	U.S. Metric	Unit of measure depends on value selected for P12. Set to 10 (100 for metric units) for proper operation.
P4	Factor B	0.2 to 51.0 0.1 to 25.5	0.2 0.1	0.2 0.1	U.S. Metric	Unit of measure and default depends on value selected for P12. Set to .5 (.1 for metric units) for proper 960i operation.
P5	Capacity of unit	0.1 to 140.0 0.01 to 14.00	0.1 0.01	1.0 0.1	Gallons/100 Cubic Meters/ 10	Unit of measure depends on value selected for P12. Enter the unit capacity in gallons/100 (cubic meters/10 if metric units).



**Table 2 - Level II Programming Parameters**

Parameter		Range of Values	Minimum Increments	Default	Units of Measure	Notes
Name	Description					
P6	Refill Control Value	1 to 99	1	99		Set to 99 for 960F operation. Skip for default.
P7	Brine draw value	1 to 99	1	99		Set to 99 for 960F operation.
P8	Not used	NA	NA	NA	NA	NA
P9	Backwash time	3 to 30	1	14	Minutes	Enter the desired backwash time in minutes. Skip for default.
P10	Slow Rinse time	8 to 125	1	8	Minutes	Set to 8 minutes for 960F operation.
P11	Fast Rinse time	2 to 19	1	9	Minutes	Enter the desired fast rinse time in minutes. Skip for default.
P12	Units of measure	0 to 1	1	0		0=U.S., 1=Metric. Skip this parameter to accept U.S. or enter 1 for Metric.
P13	Clock mode	0 to 1	1	0		0=12-hour clock, 1=24-hour clock. Skip this parameter for a 12-hour clock or enter 1 for a 24-hour clock.
P14	Calendar override	0 to 30	1	0	Days	0=no calendar override. Skip this parameter for no calendar override or enter a value.
P15	Reserve type	0 to 3	1	0		0=variable reserve, 1=fixed reserve, 2=variable reserve with immediate backwash, 3=fixed reserve with immediate backwash. Skip this parameter to accept the default or enter a different reserve type.
P16	Fixed reserve capacity or initial average value	0 to 70	1	30	Percent of capacity	Description depends on the value entered for P15. Skip this parameter to accept the default or enter a different value.
P17	Operation type	0 to 1	1	4		Set to 4 for 960F operation.
P18	Factor B/ Capacity	0 to 1 change lock out	1	0		0=none, 1=Factor B/Capacity change locked out. Skip this parameter to accept the default or enter 1 to lock out Factor B/capacity change.
P19	Factory defaults	0 to 3	1	99		Loads in factory default values. <b>Do not change this parameter.</b>

## Level II Parameters

The Level II parameters are P6 through P19 in Table 2.

The Home Owners Manual for this product does not mention these parameters, so the end user does not normally have access to these values. To access Level II Parameters, simultaneously press and hold the down arrow (↓) and up arrow (↑) button for three seconds.

If the control was alternating between Time of Day and Capacity when the above button sequence is entered, the display shows P1. If a different Level I Parameter was displayed, the display, shows the “P” number for

that parameter. Refer to Table 2 to find the “P” number associated with each parameter.

Use the up arrow (↑) button or the down arrow (↓) button to move from one parameter to the next. The display cycles through the “P” numbers shown in Tables 1 and 2. When you reach P19, the display will go back to P1.

When the parameter number you want to change is displayed, press the left arrow (←) button to display the data assigned to that parameter. Press the **SET** button

---

---

and the far right digit on the display starts flashing. If you want to change this number, press the up arrow (↑) button or the down arrow (↓) button. To skip the number without changing, press the left arrow (←) button. When the number is correct, press the **SET** button. The numbers stop flashing and the control accepts the new setting. If the new setting was not accepted, the display will show the previous setting. Refer to Table 2 for allowable values for that parameter.

To change or view other parameters, press the left arrow (←) button to have the display show “P” numbers. Now use the up arrow (↑) button or the down arrow (↓) button to move to the parameter number you wish to change.

To exit the Level II programming mode, simultaneously press and hold the down arrow (↓) and up arrow (↑) buttons for three seconds, or wait 30 seconds without pressing a button. The control starts alternating the display between Time of Day and Capacity.

## Refill Control

The Performa Valve with the 960F control is designed for use as a three cycle filter valve and does not include a refill control. However, the software program used in the 960F control is also used for the five cycle softener control, and requires a refill controller value to calculate how long to pause the cam shaft in the refill position. In general, a small refill control value results in a long pause, and a large refill control value results in a short pause. For 960F operation, the refill Control Value should be set to 99 to avoid delays during backwash. The default value for Refill Control Value is 99.

## Brine Draw Value

Brine Draw Value P7 is used to calculate the amount of time required for the brine draw cycle. Because the 960F does not require a brine draw cycle, the Brine Draw Value should be set to 99 to avoid delays during backwash.

- This control does not use parameter P8. No entry is needed for this parameter.

## Backwash Time

Parameter P9 is used to set the backwash time in minutes. The default in P9 is 14 minutes. If a different backwash time is desired, press the **SET** button and enter a new value.

## Slow Rinse Time

Parameter P10 Slow Rinse Time is used to calculate how long to pause the cam shaft for the slow rinse cycle. For 960F operation, the Slow Rinse time should be set to 8 minutes to avoid delays during backwash. The default value for Slow Rinse Time is 8 minutes.

## Fast Rinse Time

Parameter P11 determines the fast rinse time. The default value is 9 minutes. If a different fast rinse time is desired, press the **SET** button and enter a new value.

- Parameter P12 selects the units of measure. Be sure that this is set to the correct value before entering any data for parameters P3, P4, or P5.
- Parameter P13 selects the clock display mode. If the 12 hour mode is selected, a PM indicator is used. If the 24 hour mode is selected, the indicator is not used.
- Parameter P14 is used to set the calendar override feature. The default value is zero. If set to zero, the feature is disabled. Refer to Calendar Override for more information on the calendar override feature.
- Parameter P15 selects a variable reserve type, 0 to 3. For more information on reserve options, refer to Reserve Options.
- Parameter P16 is used to calculate the initial average daily water usage values. The control multiplies the total capacity by the percentage entered for Parameter P16 and uses that value as the initial average daily usage for each day of the week until water usage establishes new averages. The default is set for 30% of the capacity. In most installations this is acceptable.
- Parameter P17 has been preset to 4. **Do not change this setting.** P17 must be set to 4 for proper 960F operation. Improper backwashes will occur if P17 is set to something other than 4.
- Parameter P18 allows the installer to lock the Factor B and Capacity values so they cannot be changed. When Parameter 18 is set to 1, those two settings can only be viewed when the control is in the Level II mode. The settings will be skipped when the control is in the Level I mode. When Parameter 18 is set to zero, the Factor B and Capacity can be viewed and changed in either Level I or Level II.
- Parameter P19 is used at the factory to enter default values. **This parameter does not need to be changed.** Using this parameter will erase the values for all other parameters and replace them with default values. P19 should be set at 99 and should not be changed.

---

---

## Regeneration

When the control begins a regeneration, the display will alternate between Time of Day and Regen Time Remaining. The Regen Time Remaining is shown in minutes. The control will start and stop an internal motor which drives the cam gear through the various backwash positions. The control uses the information entered in the parameters shown in Table 2 to determine how long each part of the cycle should last.

If power fails during a regeneration cycle, the cycle completes normally when the power is restored.

**Note:** The **REGEN** button is only active when the display is alternating between Time of Day and Capacity. When programming Level I or II parameters, the **REGEN** button is not active.

The Regen Time Remaining will continue to count down until the cam gear reaches the Service position.

## Manual Regeneration

To initiate a manual regeneration, press the **REGEN** button. This button is located on the front of the control. When you press the **REGEN** button, the control performs a full regeneration of the filter.

**If you press this button again more than one minute after regeneration begins, but before the regeneration is complete, a second regeneration will start when the first regeneration is finished.** The display will freeze and only show the Regen Time Remaining as an indication that the second regeneration will be performed. When the first regeneration is complete, the second one will begin and the display will alternate between Time of Day and Regen Time Remaining.

## Automatic Regeneration

There are two ways to have the control automatically initiate a regeneration: calendar override or normal metered water usage.

### Calendar Override

This feature is set in parameter P14. It can be set for 1 to 30 days. If it is set to zero, this feature is disabled. When this feature is active, the control keeps track of the number of days since the last backwash and when that number equals the value set in P14, a backwash is automatically started at the Time of Backwash set in P2.

## Normal Metered Water Usage

The control compares the water usage to the calculated volume capacity of the system. The control uses the Capacity parameter P5 and the Factor A parameter P3 to calculate the volume capacity of the system. It also uses a reserve value to determine if a backwash is necessary. If the water usage since the last backwash is greater than the system capacity minus the reserve, a backwash is needed.

**Note:** If the water usage exceeds 150% of the system capacity between backwashes, the control will automatically call for a second backwash the next day even if no water used.

## Reserve Options

There are two types of reserve options for this control: fixed reserve and historical water usage pattern. They are selected with parameter P15.

### Fixed Reserve

When the fixed reserve is selected, the control multiplies the maximum system capacity by the percent value set in parameter P16 and uses the result as a reserve.

### Water Usage Pattern

The other reserve option allows the control to adjust the reserve based upon the historical water usage pattern of the system. The control keeps track of the water usage for each day of the week and uses that day's average usage multiplied by 1.2 as the reserve for that day. Every day at the Time of Backwash, the control recalculates the day's average water usage. If less than 10% of a day's average water usage is used, the control will not change the day's average. If more than twice the day's average is used, the control uses the actual usage in the reserve calculation.

Since a new installation has no history of water usage, the control multiplies the percent of capacity value set in parameter P16 by the total system capacity to determine starting average for each day of the week. The factory set default value for P16 is 30 which means that 30% of the total system capacity is used for the starting average for each day.

Program parameter P15 is also used to select whether the control waits until the Time of Backwash set in parameter P2 to start a backwash, or if the control should begin a backwash immediately when the capacity remaining is less than the reserve.

## Removing the Valve Assembly for Servicing

1. Unplug the power cord.
2. Shut off water supply or put bypass valves into bypass position.
3. Remove cover and with screwdriver, relieve tank pressure by pushing open valve No. 7 (rear flapper) on control as shown (Figure 8).

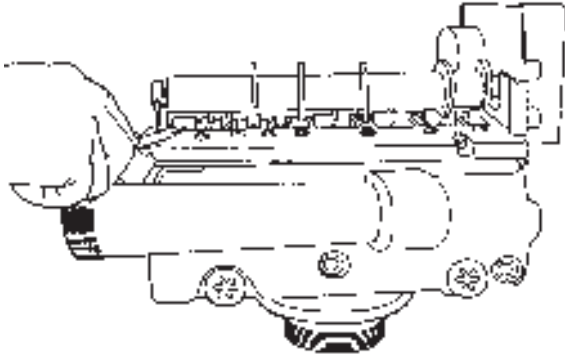

Figure 8

4. When used with a globe valve bypass, loosen and detach the inlet, outlet, brine and drain lines from the valve. If using the 1265 bypass, loosen and remove valve from bypass as well as loosening and removing the brine and drain lines.
5. Unscrew (counterclockwise) and remove valve from tank.
6. To replace the control valve, reverse the above procedure.

## Removing 440i for Servicing

1. Unplug the power cord.
2. Remove the cover.
3. Align the indicator arrow on the rear of the camshaft with the top of the rear hoop of the top plate (Figure 9).

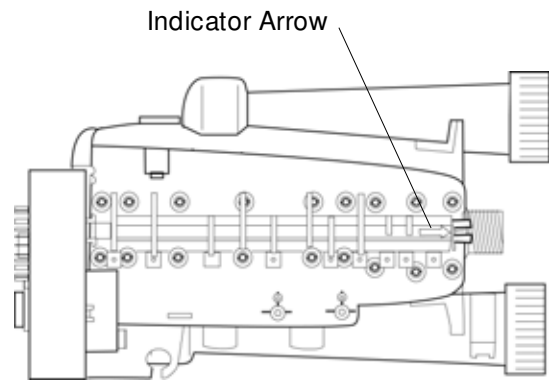

Figure 9

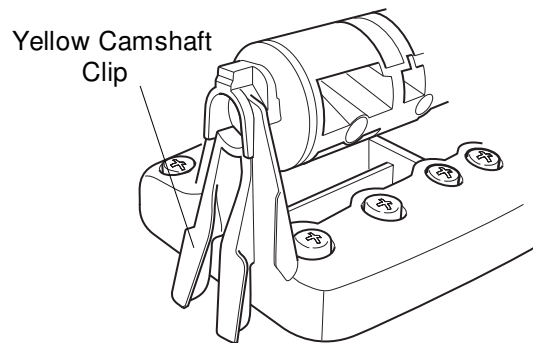

Figure 10

4. Remove the yellow camshaft clip, located at the rear of the camshaft (Figure 10) to remove the camshaft. Push the two ends of the clip together (Figure 11) to remove the clip from the back.

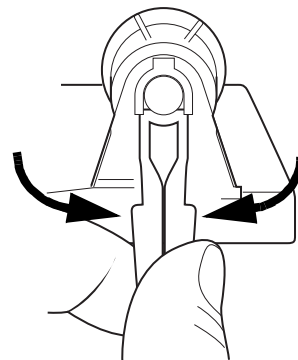

Figure 11

- Remove the yellow camshaft clip from the rear top plate hoop (Figure 12).

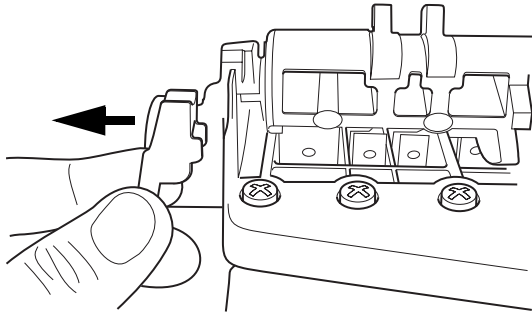

Figure 12

- Disengage the front of the camshaft from the output gear of the control.
- Remove the timer locking pin and lift the control straight up and off of the valve.
- Reverse the above procedures to reinstall the camshaft and control.

### Removing the 940F and 960F Controls For Servicing

Complete the following steps to remove the 940F and 960F control for servicing:

- Unplug the wall-mount transformer.
- Shut off the water supply or put the bypass valve(s) into bypass position.
- Remove the rear cover by depressing the two tabs provided on the cover, (Figure 13). Lift the front of the cover and remove to expose the valve body.

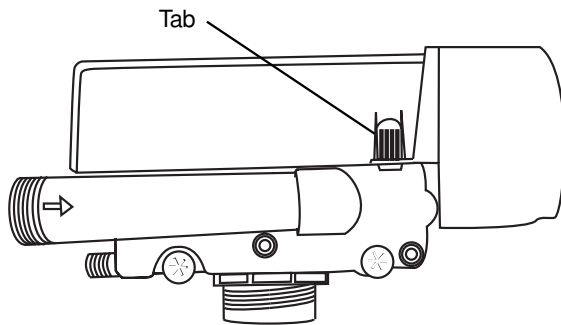

Figure 13

- Relieve system pressure by opening the Backwash Drain Valve (the seventh valve back from the control) with a screwdriver, (Figure 14).

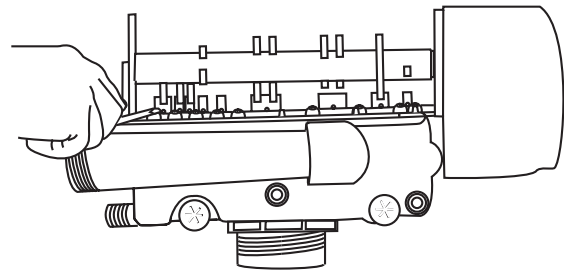

Figure 14

- To remove the camshaft or to reinstall it, the arrow on the shaft must be pointing at the line on the rear "hoop" of the top plate. This occurs when the indicator knob is rotated to the refill position. Press down on the back of the camshaft to disengage it from the rear "hoop" of the top plate, (Figure 15). Slide the camshaft back to disengage it from the timer, (Figure 16).

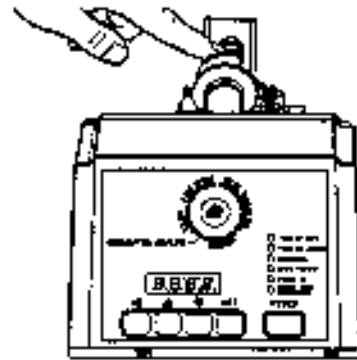

Figure 15

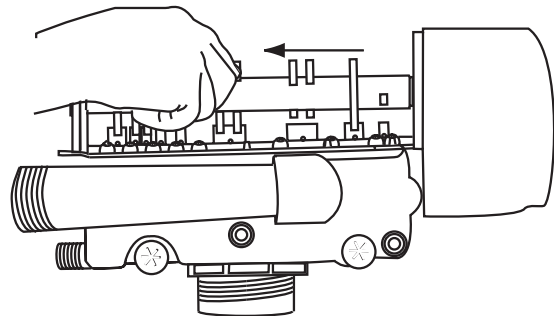

Figure 16

- Disconnect the turbine probe from the turbine assembly.
- Lift the control off the valves, Figure 17. To replace the control, reverse the above procedure. Note that the camshaft needs to be positioned correctly before it can be inserted into the back of the

control. There is a locating rib on the camshaft. Position the rib on the top of the shaft and slide the camshaft into the control. Push up on the end of the camshaft, furthest from the timer, snapping it into place.

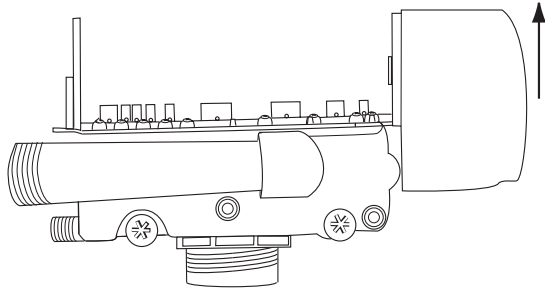

Figure 17

## Preventive Maintenance

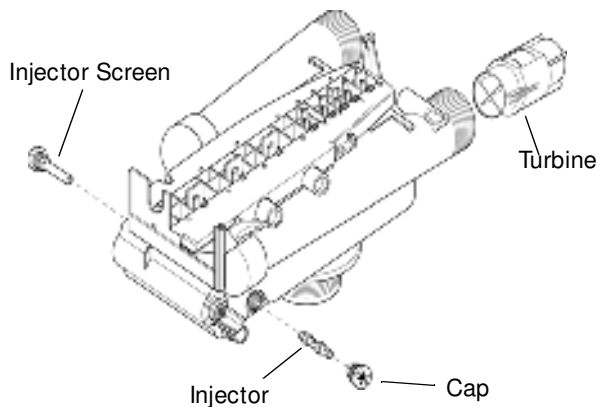

Figure 18

## Water Meter Maintenance

Note: A water meter is used only with the 960F control. If you are using the 440i or 940F control, this section does not pertain to your conditioner.

The metering device used with the 960 demand controls may require simple maintenance. In rare

instances, the turbine wheel of the water meter can collect small particles of oxidized iron, eventually preventing the wheel from turning.

1. Shut off the water supply or put the bypass valve(s) into the bypass position.
2. Relieve pressure by opening the Backwash Drain Valve (the seventh back from the control) with a screwdriver (Figure 14).
3. Loosen and remove the pipe/tube adapters or 1265 bypass from the inlet and outlet of the valve body.
4. Using a needle-nose pliers, remove the turbine from the outlet housing. Grasp one of the four vanes of the outer gland and pull straight out to remove turbine assembly from the outlet of the valve (Figure 18).
5. Carefully remove the turbine wheel from the housing. Use a toothbrush to lightly scrub the iron off the magnet. Iron buildup on the surfaces can be removed by soaking the wheel in a mild sodium hydrosulfite (such as RoVer\*) solution for a few minutes. Flush thoroughly with water.
6. Carefully reinstall the turbine wheel into the turbine cage housing. Make sure that the shaft of the wheel seats into the bearing of the cage. Reassemble the turbine cage and check that the wheel rotates freely.
7. Reinstall the turbine cage into the outlet of the valve.
8. Reinstall the pipe/tube adapters or 1265 bypass to the inlet and outlet of the valve.
9. Turn on the water supply or put the bypass valve(s) into the service position and purge the air out of the system.

To check for proper meter operation, open a downstream faucet and observe the water flow indication on the control display.

# Specifications

## 263/440i Drawings

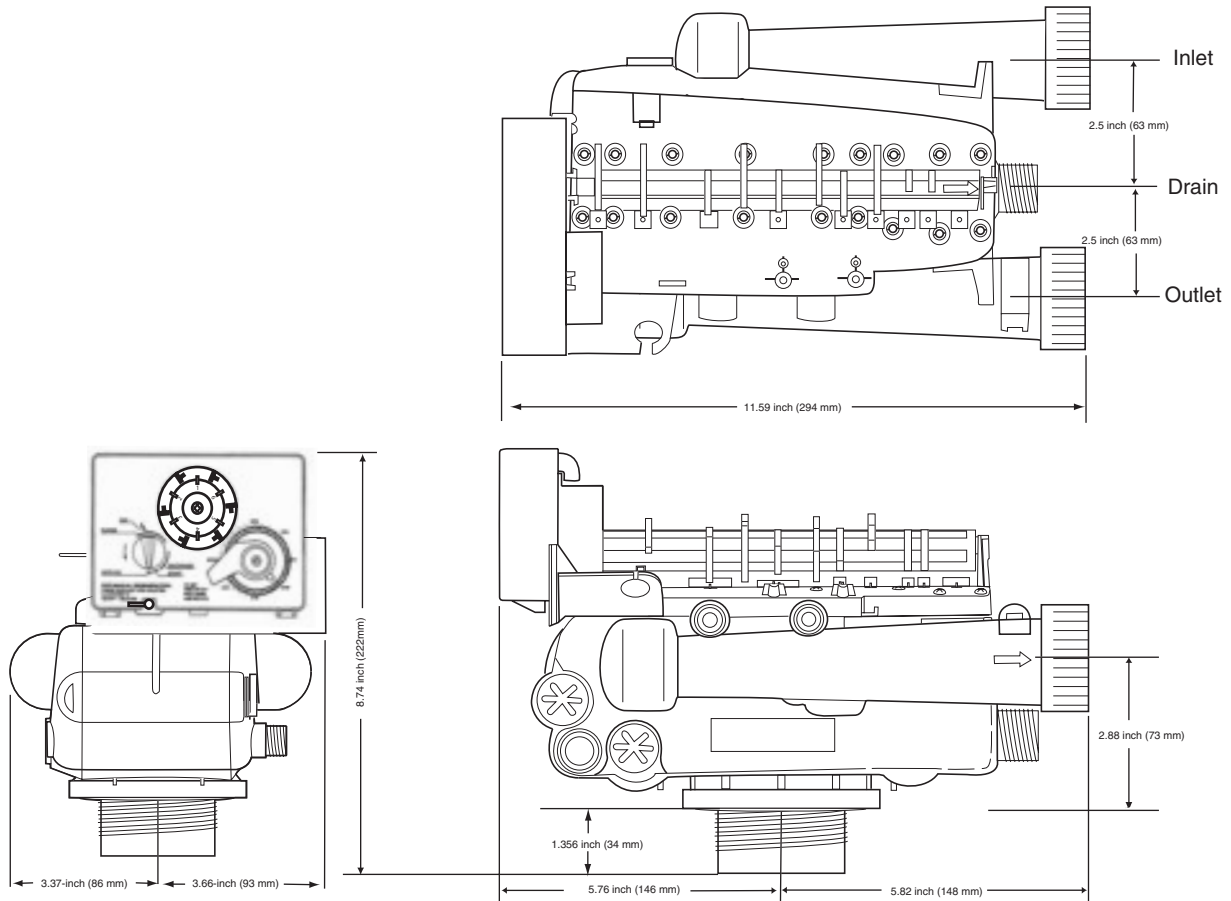

Hydrostatic Test Pressure . . . . .	300 psi (20.69 bar)
Working Pressure. . . . .	20-125 psi (1.38 - 8.62 bar)
Standard Electrical Rating . . . . .	115V 60 Hz
Optional Electrical Rating . . . . .	115V 50 Hz, 230V 50 Hz, 200V 60 Hz, 24V 60 Hz, 24V 50 Hz, 100V 60 Hz, 100V 50 Hz, 12V 50 Hz/transformer, 12V 60 Hz/transformer
Electrical Cord (standard rating) . . . . .	60 inch (1.5 m) 3-wire with plug
Pressure Tank Thread . . . . .	2 1/2 inch-8 male
Riser Pipe Diameter Required . . . . .	1.050 inch OD (26.7 mm)
Riser Pipe Length . . . . .	1-1/8 ± 1/8 inches (31.8 mm) higher than the top of mineral tank
Standard Connection . . . . .	.1-inch (25.4-mm) copper tube adapters
Optional Connections . . . . .	.3/4-inch, 22-mm, and 28-mm copper tube adapters 3/4-inch BSPT, 1-inch BSPT, 1-inch NPT brass pipe adapters 3/4-inch, 1-inch, 25-mm CPVC tube adapters
Drain Line Connection. . . . .	3/4-inch NPT male
Optional Bypass Valve. . . . .	Rotating handles, full 1-inch porting, reinforced Noryl
Control Module, Tank Adapter. . . . .	Reinforced Noryl
Rubber Goods . . . . .	Compounded for cold water service
Program Clock (Timer). . . . .	440i: Available in 6 - or 7-day English, German, French, Italian, Spanish, Japanese 940F: Available in 7 - or 12-day English, German, French, Italian, Spanish, Japanese 960F: Available in English, German, French, Italian, Spanish, Japanese
Internal Backwash Controllers. . . . .	7- through 14-inch (17.8- though 35.6-cm) diameter media tanks

All sizes to flow 4.5 gpm/sq ft (183 L/m/m<sup>2</sup>) of bed area. For tank sizes above 14 inches in diameter, use an external flow control.

# 263/900 Series Drawings

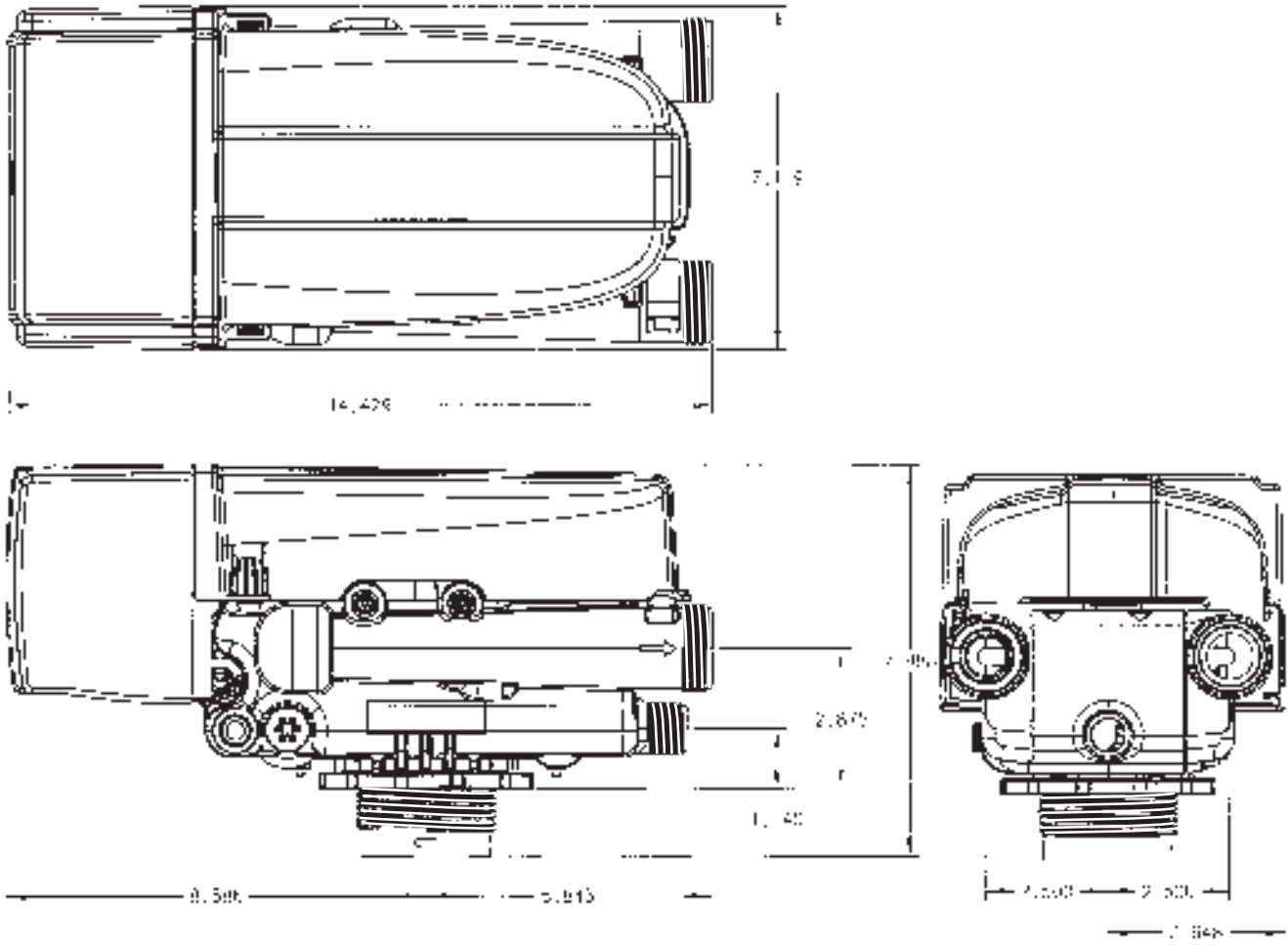



## Control Valving Identifications

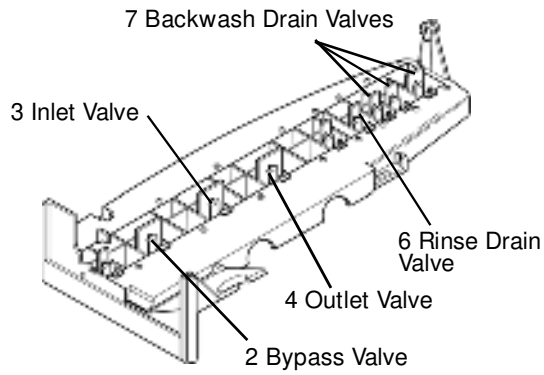

## Valve Disc Operation

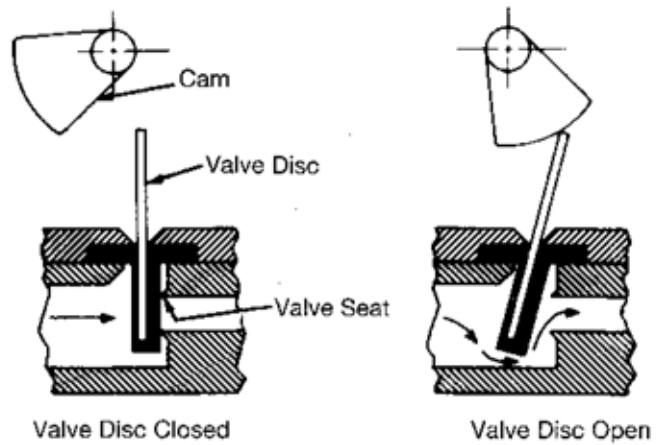

## Flow Diagrams

### 1 Treated Water Position

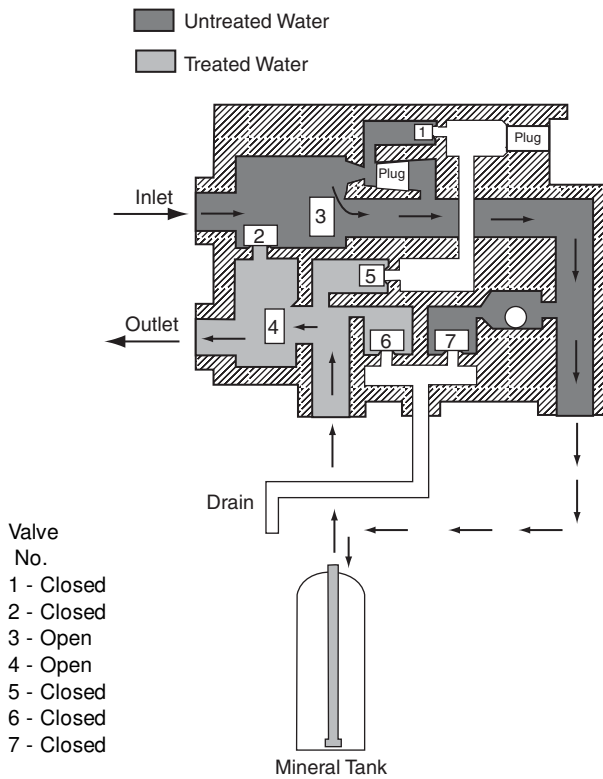

### 2 Backwash Position

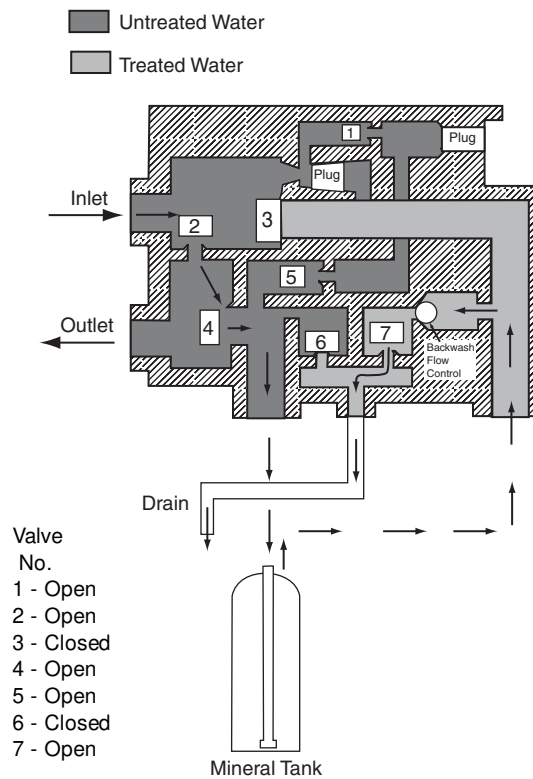

### 3 Fast Rinse Position

Untreated Water  
 Treated Water

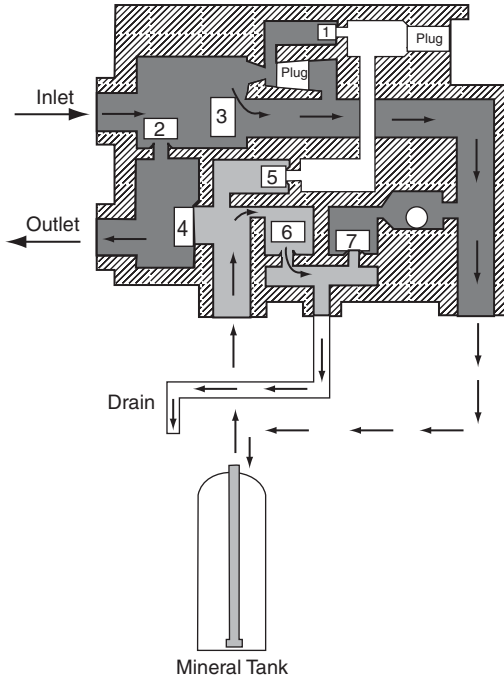

# Performa Valve Replacement Parts

## Performa Valve

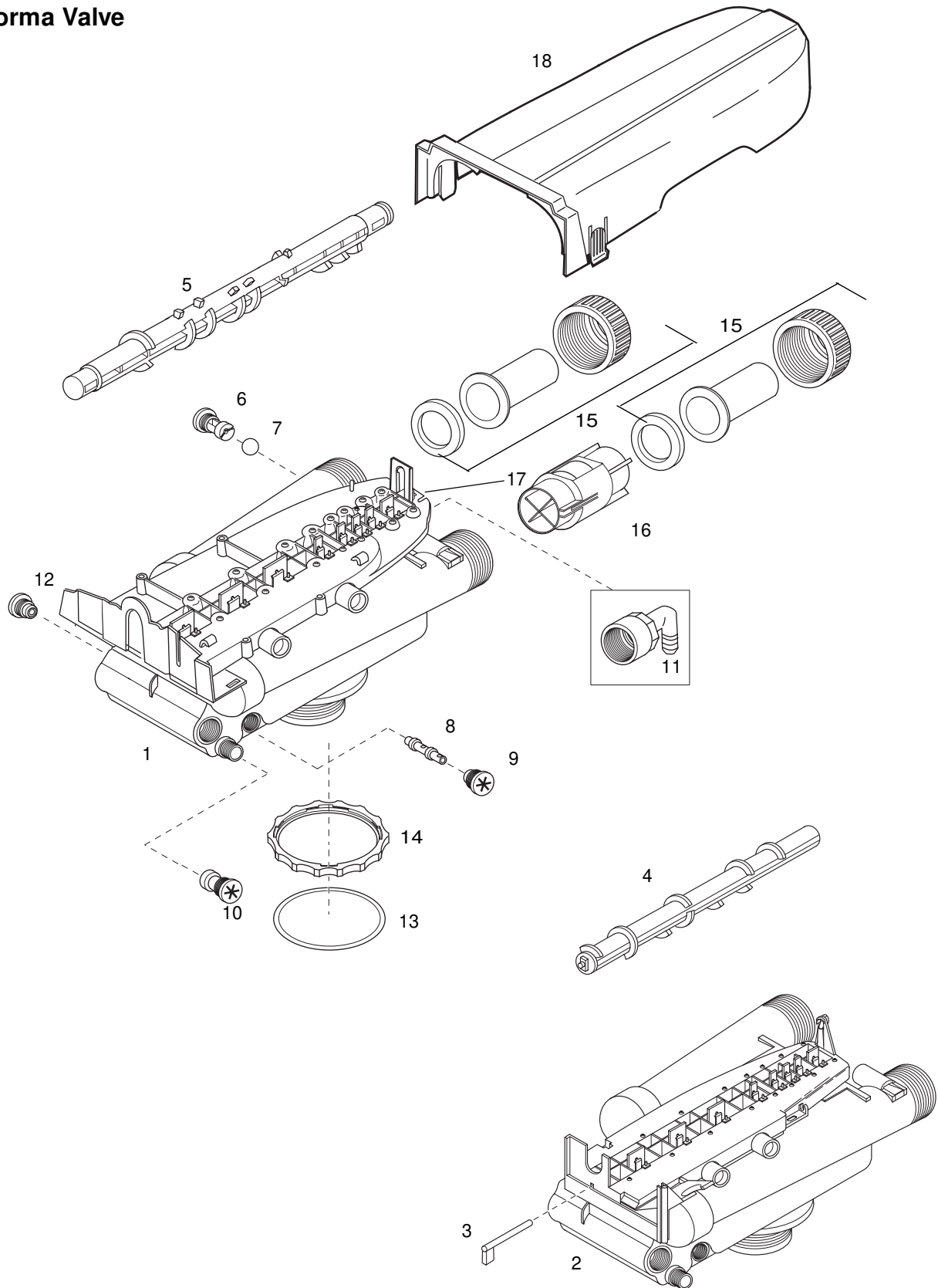

## Parts List

Part				Part			
Code	No.	Description	Qty.	Code	No.	Description	Qty.
				10	1030334	Plugged Brine Refill Control	1
1	1035807	Valve Assy, w/o Flow Controls (940F, 960F)	1	11	1002449	Drain Fitting Elbow (3/4" hose barbed)	1
2	1035606	Valve Assembly, w/o Flow Controls (440i)	1	12	1000226	Cap Assembly	1
3	1031391	Timer Locking Pin	1	13	1010429	O-Ring	1
4	1035624	440i Filter Camshaft (Grey)	1	14	1035622	Tank Ring	1
5	1030380	940F, 960F Filter Camshaft		15		Plumbing Adapter Kits:	1
6		Drain Control Assembly:	1		1001606	3/4-inch Copper Tube Adapter Kit	
	1000209	No. 7 (1.2 gpm; 4.5 Lpm)			1001670	1-inch Copper Tube Adapter Kit	
	1000210	No. 8 (1.6 gpm; 6.1 Lpm)			1041210	1-1/4-inch copper Tube Adapter Kit	
	1000211	No. 9 (2.0 gpm; 7.6 Lpm)			1001608	22-mm Copper Tube Adapter Kit	
	1000212	No. 10 (2.5 gpm; 9.5 Lpm)			1001609	28-mm copper Tube Adapter Kit	
	1000213	No. 12 (3.5 gpm; 13.2 Lpm)			1001613	3/4-inch CPVC Tube Adapter Kit	
	1000214	No. 13 (4.1 gpm; 15.5 Lpm)			1001614	1-inch CPVC Tube Adapter Kit	
	1000215	No. 14 (4.8 gpm; 18.2 Lpm)			1001769	3/4-inch NPT Plastic Pipe Adapter Kit	
7	1030502	Ball, Flow Control	2		1001603	1-inch NPT Plastic Pipe Adapter Kit	
8	1032978	Plugged Injector Assembly	1		1001604	3/4-inch BSPT Plastic Pipe Adapter Kit	
9	1000218	Injector Cap Assembly	1		1001605	1-inch BSPT Plastic Pipe Adapter Kit	
					1001611	3/4-inch BSPT Brass Pipe Adapter Kit	
					1001610	1-inch NPT Brass Pipe Adapter Kit	
					1001612	1-inch BSPT Brass Pipe Adapter Kit	
				16	1033444	Turbine Assembly (960F only)	1
				17	1001580	Spring, Flapper Valve	
				*		Valve Disc Kit:	
					1041174	Standard	
					1041175	Severe Service	
				*	1000062	I-Lid Cover	1

## 440i Control

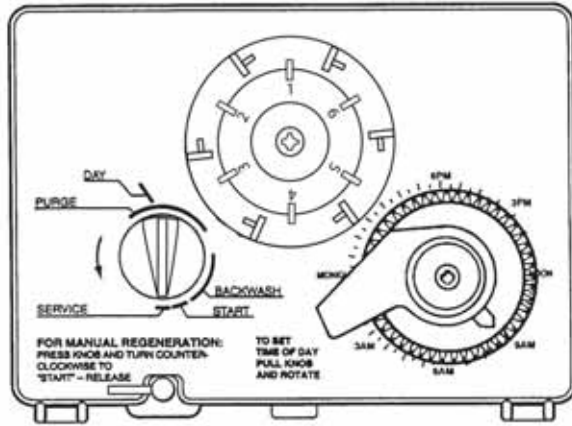

1

## 940F Control

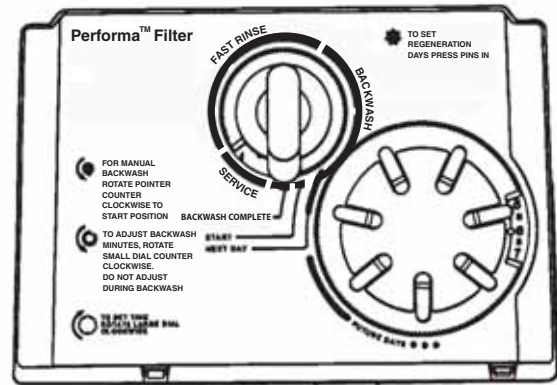

2

## 960F Control

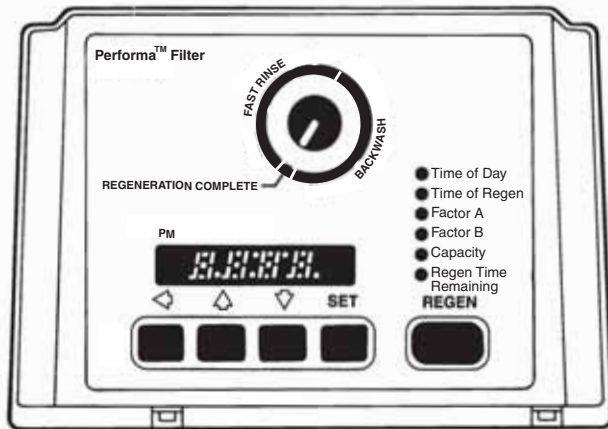

3

## 1265 Bypass

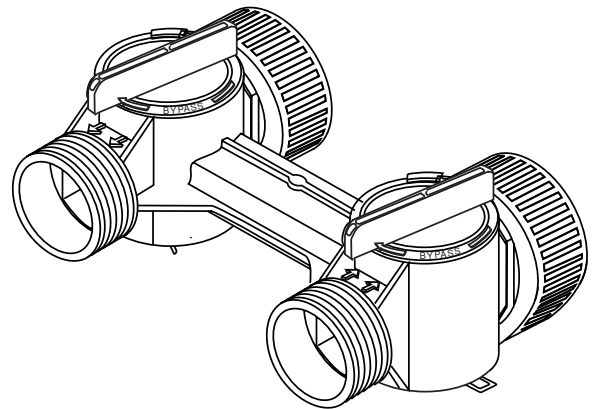

4

Part			
Code	No.	Description	Qty.
1		440i Control (6 day or 7 day)	1
2		940F Control (7 day or 12 day)	1
3		960F Control	1
4	1040930	1265 Bypass	1
*	1000811	Transformer (440i, 460i, 960):	1
*	1000907	Transformer Extension Cord 15 feet (4.6 m)	1
*	1034264	Y-Splitter (run 2 units from 1 trans- former)	1

\*Not Shown

## Troubleshooting

The technology upon which the Autotrol Performa control valve is based is well established and proven in service over many years. However, should a problem or question arise regarding the operation of the system, the control can very easily be serviced. For parts mentioned, refer to exploded views in the **Replacement Parts** section of this manual.

**IMPORTANT:** Service procedures that require the water pressure to be removed from the system are marked with a ! after the possible cause. To remove water pressure from the system, put the bypass valve or three-valve bypass into the bypass position and open the backwash drain valve (the seventh valve back from the control) with a screwdriver. Restore system water pressure when the service work is completed.

### Valve Troubleshooting

Problem	Possible Cause	Solution
1. Control backwashes at excessively low or high rate.	<ul style="list-style-type: none"> <li>a. Incorrect backwash controller used.</li> <li>b. Foreign matter affecting controller operation !</li> </ul>	<ul style="list-style-type: none"> <li>a. Replace with correct size controller.</li> <li>b. Remove controller and ball. Flush with water.</li> </ul>
2. Untreated water leakage during service.	<ul style="list-style-type: none"> <li>a. Improper regeneration.</li> <li>b. Leaking of bypass valve !</li> <li>c. O-ring around riser tube damaged !</li> </ul>	<ul style="list-style-type: none"> <li>a. Repeat regeneration making certain that the correct salt dosage is set.</li> <li>b. Replace O-ring.</li> <li>c. Replace O-ring.</li> </ul>

### 440i and 940F Control Troubleshooting

Problem	Possible Cause	Solution
1. Control will not regenerate automatically.	<ul style="list-style-type: none"> <li>a. Transformer or motor not connected.</li> <li>b. Defective timer motor.</li> <li>c. Skipper pins not down on timer skipper wheel.</li> <li>d. Binding in gear train of timer.</li> </ul>	<ul style="list-style-type: none"> <li>a. Connect power.</li> <li>b. Replace motor.</li> <li>c. Depress pins for days regeneration required.</li> <li>d. Replace timer.</li> </ul>
2. Control regenerates at wrong time of day.	<ul style="list-style-type: none"> <li>a. Time set incorrectly.</li> </ul>	<ul style="list-style-type: none"> <li>a. Correct time setting according to instructions.</li> </ul>

## 960F Control Troubleshooting

### Alarms

The Model 960 continuously monitors itself and sounds an alarm if it detects something wrong. The alarm is a beep that is on for one second and then off for nine seconds. When the alarm sounds, the display shows the letters "Err" with a number from 1 to 4. The table

below lists the Err numbers, a description of each error, the cause of the error, and the solutions. To silence the alarm, press any button on the control. If the error still exists, the control will go back to the alarm condition after 30 seconds.

### Model 960 Alarms

Indication	Description	Cause	Solution
Err 1	Electronics Failure	Control settings need reprogramming.	Press any key to load default values. Refer to "Programming the Model 960 Control".
Err 2	Improper start of regeneration (limit switch closed when it should be open).	Valve camshaft has been manually rotated during a regeneration. Valve camshaft has been manually rotated out of "regeneration complete" position. Faulty motor. Faulty motor drive. Faulty switch.	Press any key to silence the alarm. (Note: Alarm automatically clears at "TIME OF REGEN".) The control will turn the motor on and drive the camshaft to the proper location.  Replace the control. Replace the control. Replace the control.
Err 3	Improper finish of regeneration (limit switch open when it should be closed).	Valve camshaft has been manually rotated out of "regeneration complete" position. Faulty motor. Faulty motor drive. faulty switch.	The control will turn the motor on and drive the camshaft to the proper location.  Replace the control. Replace the control. Replace the control.
Err 4	Improper control settings (one or more settings out of the allowable range).	One or more settings out of the allowable range.	Hardness: Adjust range: 3 to 250. Capacity: Adjust range: 0.1 to 140.0. Refill control: Adjust range: 1 to 99. Brine draw value: Adjust range per Table 2.

Problem	Possible Cause	Solution
1. Capacity Display stays at 9999 even though there is water usage.	a. Total system capacity was calculated to be a value greater than 9999.	a. As the water usage continues, the remaining capacity will drop below 9999 and then other values will be shown.
2. Timer beeps when left arrow button is pressed.	a. Button is only active in the programming mode.	a. Refer to the Programming section.
3. Timer does not respond to REGEN button.	a. Button is not active in the programming mode.	a. Refer to the Regeneration section.
4. Timer does not display time of day.	a. Transformer is unplugged. b. No electric power at outlet. c. Defective transformer. d. Defective circuit board.	a. Connect power. b. Repair outlet or use working outlet. c. Replace transformer. d. Replace control.
5. Timer does not display correct time of day.	a. Outlet operated by a switch. b. Power outages.	a. Use outlet not controlled by switch. b. Reset Time of Day.

6. No water flow display when water is flowing (colon does not blink).	<ul style="list-style-type: none"> <li>a. Bypass valve in bypass position.</li> <li>b. Meter probe disconnected or not fully connected to meter housing.</li> <li>c. Restricted meter turbine rotation due to foreign material in meter !</li> <li>d. Defective meter probe.</li> <li>e. Defective circuit board.</li> </ul>	<ul style="list-style-type: none"> <li>a. Shift bypass valve into service position.</li> <li>b. Fully insert probe into meter housing.</li> <li>c. Remove meter housing, free up turbine and flush with clean water. Turbine should spin freely, if not, refer to the Water Meter Maintenance section.</li> <li>d. Replace control.</li> <li>e. Replace control.</li> </ul>
7. Control display is frozen at Regen Time Remaining.	<ul style="list-style-type: none"> <li>a. Back to back regenerations were requested.</li> </ul>	<ul style="list-style-type: none"> <li>a. Refer to the Manual Regeneration section.</li> </ul>
8. Control regenerates at wrong time of day.	<ul style="list-style-type: none"> <li>a. Power outages.</li> <li>b. Time of day set incorrectly.</li> <li>c. Time of regeneration set incorrectly.</li> </ul>	<ul style="list-style-type: none"> <li>a. Reset time of day to correct time of day.</li> <li>b. Reset time of day to correct time of day.</li> <li>c. Reset time of regeneration.</li> </ul>
9. Timer stalled in regeneration cycle.	<ul style="list-style-type: none"> <li>a. Motor not operating.</li> <li>b. Motor runs backwards.</li> <li>c. No electric power at outlet.</li> <li>d. Incorrect voltage or frequency (Hz).</li> <li>e. Broken gear.</li> <li>f. Defective switch.</li> <li>g. Air leak in brine connections (pressure locked flapper).</li> <li>h. Binding of camshaft.</li> <li>i. Water pressure greater than 125 psi during regeneration.</li> <li>j. Defective circuit board.</li> </ul>	<ul style="list-style-type: none"> <li>a. Replace control.</li> <li>b. Replace control.</li> <li>c. Repair outlet or use working outlet.</li> <li>d. Replace timer and/or transformer with one of correct voltage and frequency (Hz).</li> <li>e. Replace control.</li> <li>f. Replace control.</li> <li>g. Check all junction points and make appropriate corrections.</li> <li>h. Remove foreign object obstruction from valve discs or camshaft.</li> <li>i. Install pressure regulator to reduce pressure.</li> <li>j. Replace control.</li> </ul>
10. Continuous regeneration. Camshaft does not stop at the end of regeneration.	<ul style="list-style-type: none"> <li>a. Broken projection on drive gear.</li> <li>b. Defective switch.</li> </ul>	<ul style="list-style-type: none"> <li>a. Replace control.</li> <li>b. Replace control.</li> </ul>
11. Control does not regenerate automatically or when REGEN button is depressed.	<ul style="list-style-type: none"> <li>a. Transformer unplugged.</li> <li>b. No electric power at outlet.</li> <li>c. Defective motor.</li> <li>d. Broken gear.</li> <li>e. Binding in gear train.</li> <li>f. Defective switch.</li> </ul>	<ul style="list-style-type: none"> <li>a. Connect power.</li> <li>b. Repair outlet or use working outlet.</li> <li>c. Replace control.</li> <li>d. Replace control.</li> <li>e. Replace control.</li> <li>f. Replace control.</li> </ul>
12. Control does not regenerate automatically but does regenerate when REGEN button is depressed.	<ul style="list-style-type: none"> <li>a. If water flow display is not operative, refer to item 5 in this table.</li> <li>b. Incorrect program settings.</li> <li>c. Defective circuit board.</li> </ul>	<ul style="list-style-type: none"> <li>a. Refer to item 5 in this table.</li> <li>b. Set new control values. Refer to the Programming section.</li> <li>c. Replace control.</li> </ul>
13. Run out of treated water between regenerations	<ul style="list-style-type: none"> <li>a. Improper regeneration.</li> <li>b. Fouled resin bed.</li> <li>c. Incorrect factor 1 or capacity settings.</li> <li>d. Restricted meter turbine rotation due to foreign material in meter housing !</li> <li>e. Excessive water usage below 1/5 gallon per minute.</li> </ul>	<ul style="list-style-type: none"> <li>a. Repeat regeneration making certain that correct salt dosage is used.</li> <li>b. Use resin cleaner.</li> <li>c. Set to correct values. Refer to the Programming section in this manual.</li> <li>d. Remove meter housing, free up turbine, and flush with clean water. Turbine should spin freely, if not, replace meter.</li> <li>e. Repair leaky plumbing and/or fixtures.</li> </ul>