

# MODEL 2750 DOWNFLOW

## CONTROL VALVE

*Service Manual*

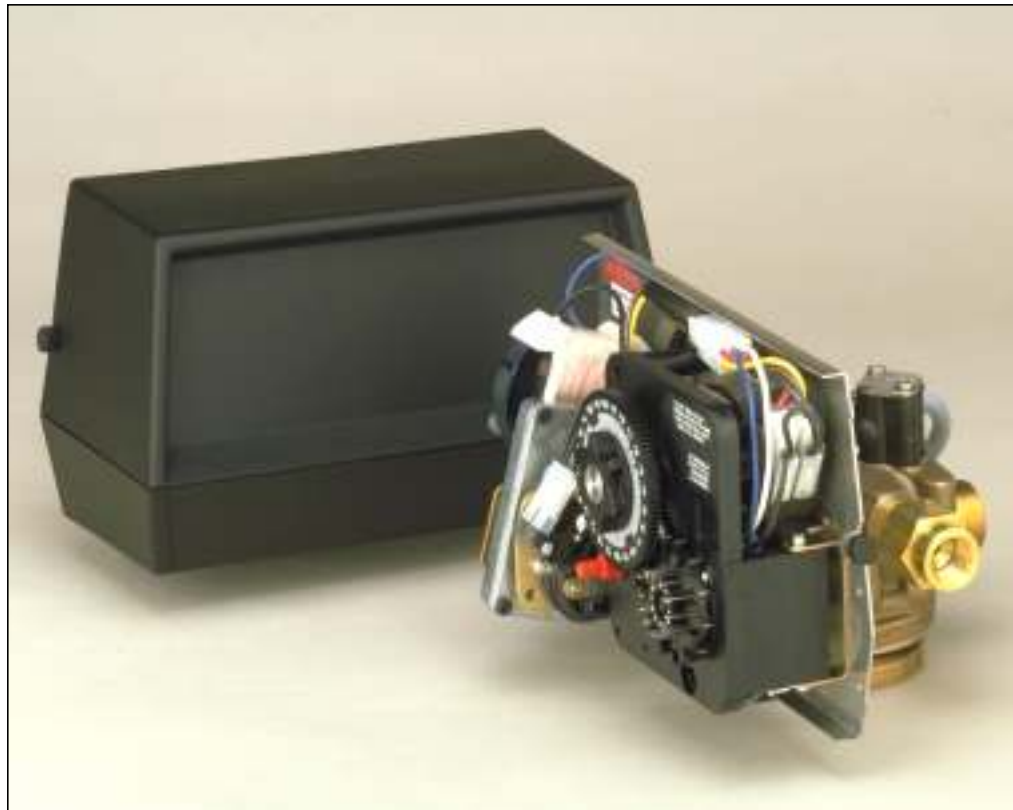

**IMPORTANT:** Fill in pertinent information on page 2 for future reference.

# MODEL 2750 DOWNFLOW

---

## Job Specification Sheet

---

\* JOB NO. \_\_\_\_\_

\* MODEL NO. \_\_\_\_\_

\* WATER TEST \_\_\_\_\_

\* CAPACITY PER UNIT \_\_\_\_\_

\* MINERAL TANK SIZE DIA. \_\_\_\_\_ HEIGHT \_\_\_\_\_

\* BRINE TANK SIZE & SALT SETTING PER REGENERATION:

\_\_\_\_\_

### \* 2750 CONTROL VALVE SPECIFICATIONS

1) Type of Timer (see pages 16,17, & 18)

A) 7 day or 12 day

B) \*310 to 5,270 gallon meter or

\*1,550 to 26,350 gallon meter

\* Other \_\_\_\_\_

C) Meter Wiring Package

1) System #4 - 1 tank; 1 meter; immediate or delayed regeneration

2) System #5 - 2 tanks; 2 meters; interlock

3) System #6 - 2 tanks; 1 meter; series regeneration

4) System #7 - 2 tanks; 1 meter; alternator

2) Timer Program Settings (see pages 18 and 19)

A) Backwash \_\_\_\_\_ min.

B) Brine & Slow Rinse \_\_\_\_\_ min.

C) Rapid Rinse \_\_\_\_\_ min.

D) Brine Tank Refill \_\_\_\_\_ min.

3) Drain Line Flow Controller \_\_\_\_\_ gpm

4) Brine Line Flow Controller \_\_\_\_\_ gpm

5) Injector Size # \_\_\_\_\_

6) Service Valve Operation Units (SVO)

Size of Service Valve \_\_\_\_\_ .

# MODEL 2750 DOWNFLOW

---

## *General Commercial Pre-Installation Check List*

---

**WATER PRESSURE:** A minimum of 25 pounds of water pressure is required for regeneration valve to operate effectively.

**ELECTRICAL FACILITIES:** A continuous 110 volt, 60 Hertz current supply is required. Make certain the current supply is always hot and cannot be turned off with another switch. (Other voltages available.)

**EXISTING PLUMBING:** Condition of existing plumbing should be free from lime and iron buildup. Piping that is built up heavily with lime and/or iron should be replaced. If piping is clogged with iron, a separate iron filter unit should be installed ahead of the water softener.

**LOCATION OF SOFTENER AND DRAIN:** The softener should be located close to a drain.

**BY-PASS VALVES:** Always provide for the installation of a by-pass valve.

**CAUTION:** Water pressure is not to exceed 120 p.s.i., water temperature is not to exceed 100° F, and the unit cannot be subjected to freezing conditions.

### INSTALLATION INSTRUCTIONS

1. Place the softener tank where you want to install the unit making sure the unit is level and on a firm base. (Maximum 4 feet apart for twin units.)
2. All plumbing should be done in accordance with local plumbing codes. The pipe size for the drain line should be the same size as the drain line flow control female connection. Water meters are to be installed on soft water outlets. Twin units with (1) one meter shall be installed on common soft water outlet of units.
3. Solder joints near the drain must be done prior to connecting the Drain Line Flow Control fitting. Leave at least 6" between the DLFC and solder joints when soldering when the pipes are connected on the DLFC. Failure to do this could cause interior damage to the DLFC.
4. Teflon tape is the only sealant to be used on the drain fitting. The drain from twin units may be run through a common line.
5. Make sure that the floor is clean beneath the salt storage tank and that it is level.
6. Place approximately 1" of water above the grid plate (if used) in your salt tank. Salt may be placed in the unit at this time.
7. On units with a by-pass, place in by-pass position. Turn on the main water supply. Open a cold soft water tap nearby and let run a few minutes or until the system is free from foreign material (usually solder) that may have resulted from the installation.
8. Place the by-pass in service position.
9. Manually index the softener control into "service" position and let water flow into the mineral tank. When water flow stops, open a cold water tap nearby and let run until air pressure is relieved.
10. Electrical: All electrical connections must be connected according to codes. Use electrical conduit if applicable. Remote meter systems and Twin meter system wiring diagrams are on page 25. Plug into power supply.

# MODEL 2750 DOWNFLOW

## Water Conditioners Flow Diagrams

### 1 SERVICE POSITION

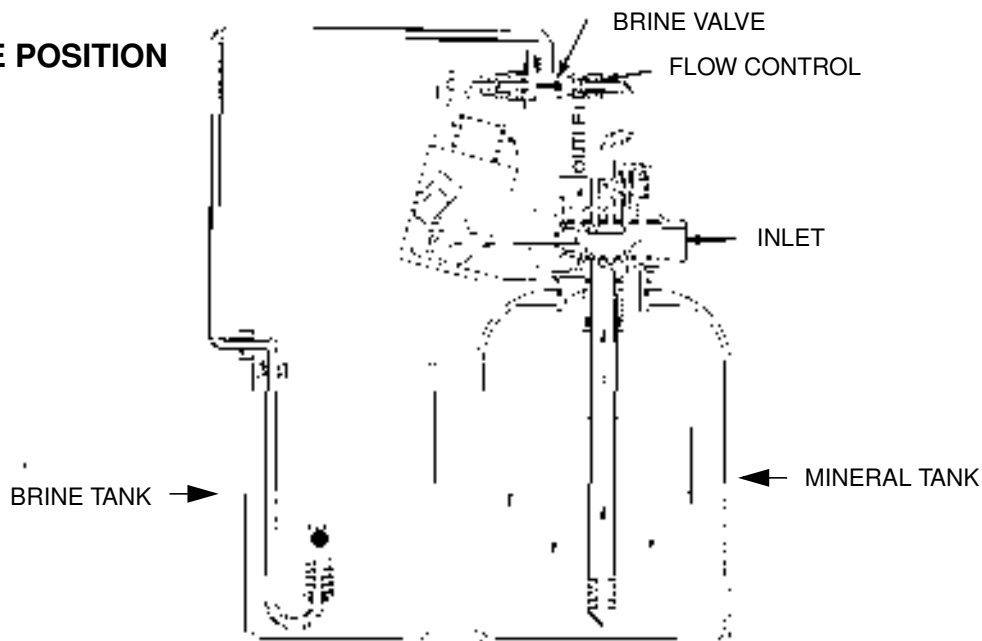

Hard water enters unit at valve inlet and flows down thru the mineral in the mineral tank. Conditioned water enters center tube thru the bottom distributor — then flows up thru the center tube — around the piston and out the top outlet of the valve.

### 2 BACKWASH POSITION

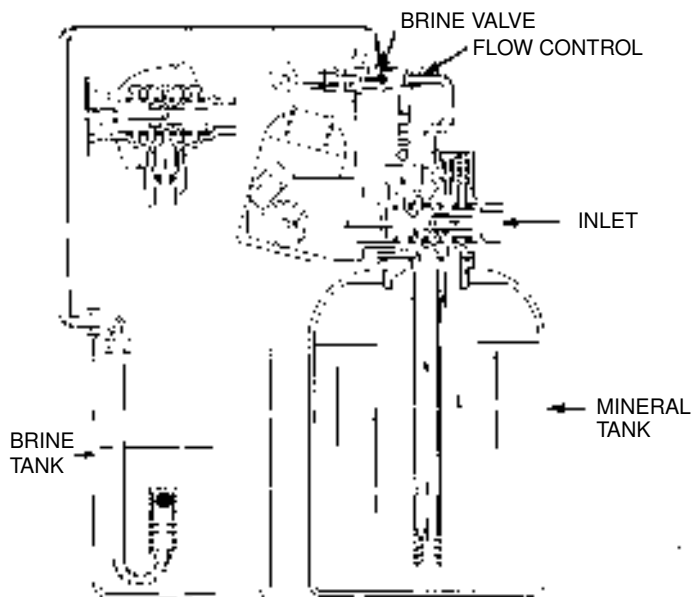

Hard water enters unit at valve inlet — flows thru piston — down center tube — thru bottom distributor and up thru the mineral — around the piston and out the drain line.

### 3 BRINE POSITION

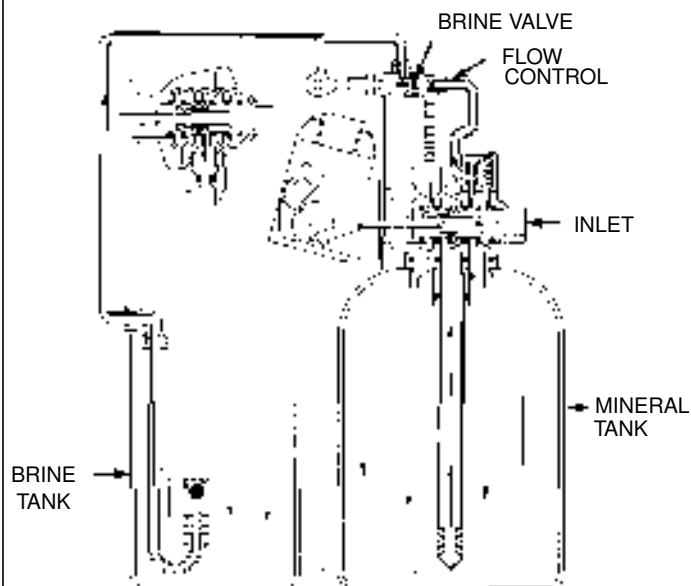

Hard water enters unit at valve inlet — flows up into injector housing and down thru nozzle and orifice to draw brine from the brine tank — brine flows down thru mineral and enters the center tube thru bottom distributor and out thru the drain line.

# MODEL 2750 DOWNFLOW

## Water Conditioners Flow Diagrams (Cont'd.)

### 4 SLOW RINSE POSITION

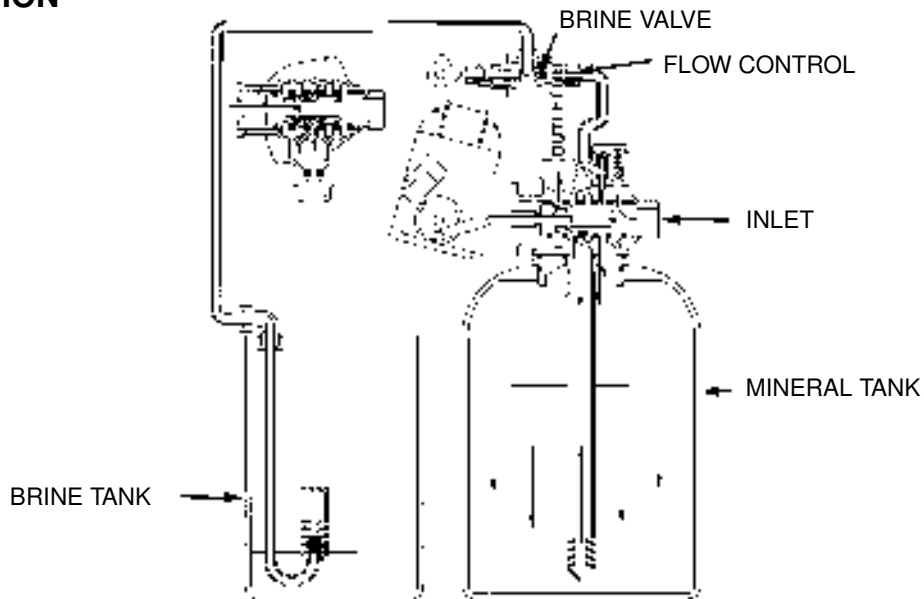

Hard water enters unit at valve inlet — flows up into injector housing and down thru nozzle and orifice — around the piston — down thru mineral — enters center tube thru bottom distributor — flows up thru center tube — around piston and out thru drain line.

### 5 RAPID RINSE

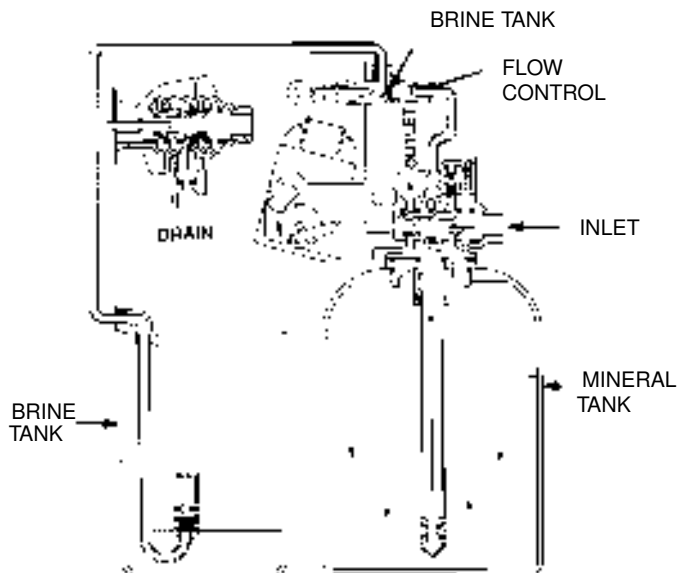

Hard water flows directly from inlet down thru mineral into center tube bottom distributor and up thru center tube — around piston and out thru the drain line.

### 6 BRINE TANK FILL POSITION

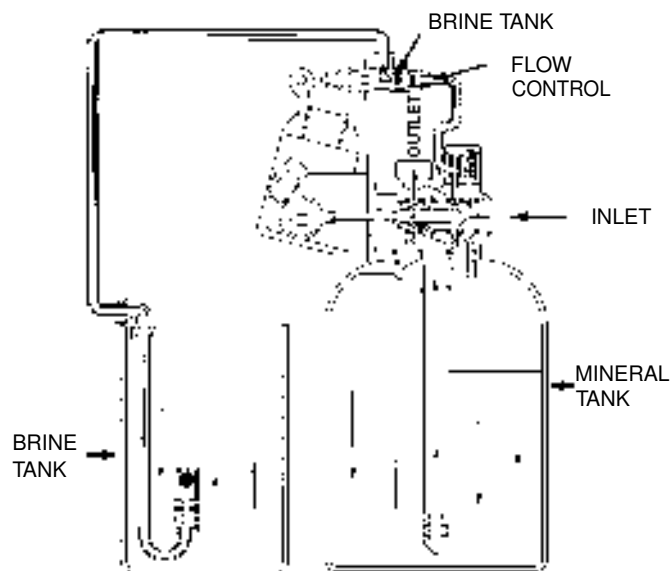

Hard water enters unit at valve inlet — flows up thru the injector housing — thru the brine valve to fill the brine tank.

# MODEL 2750 DOWNFLOW

## Control Drive Assembly

(see opposite page for parts list)

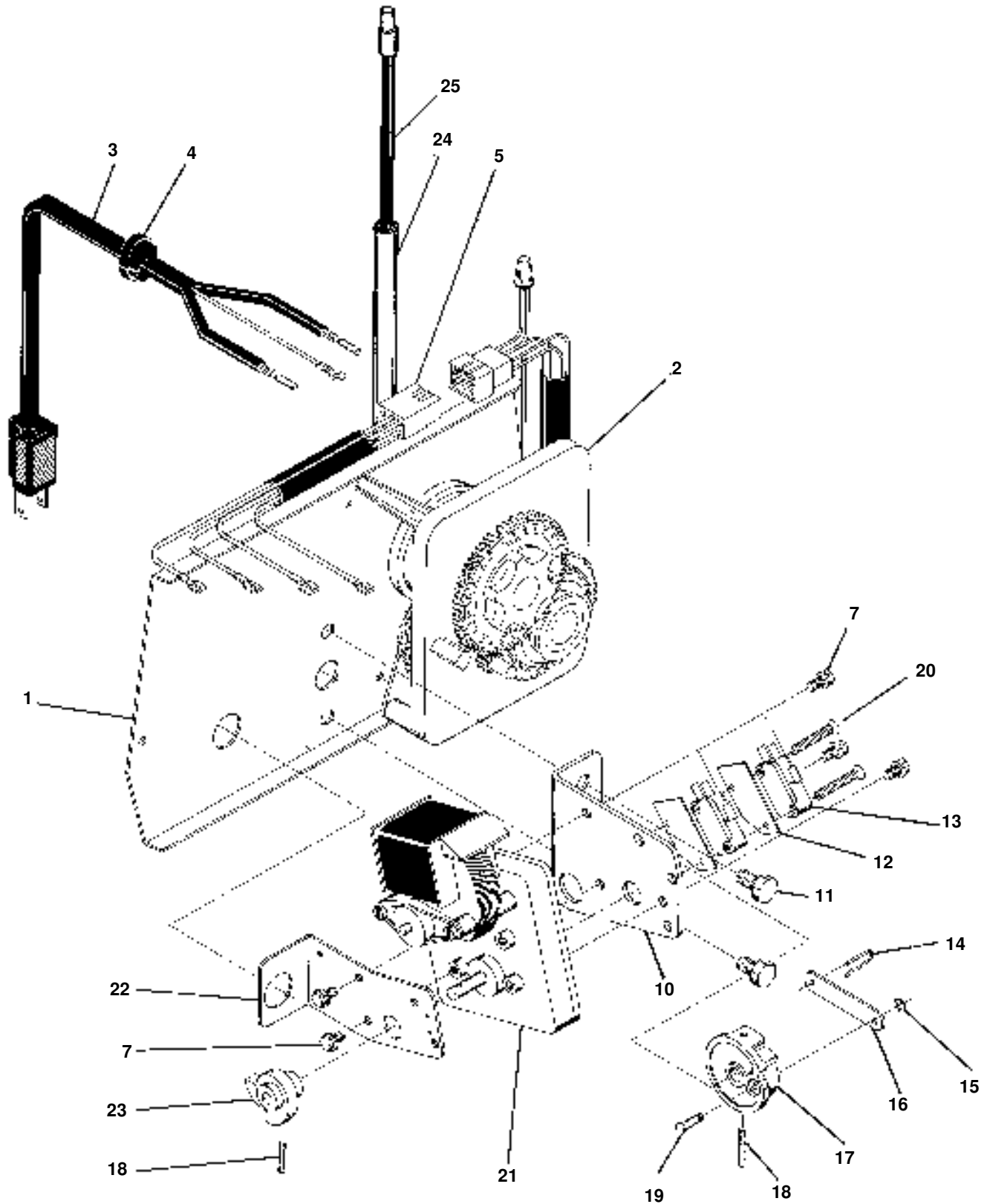

# MODEL 2750 DOWNFLOW

## Control Drive Assembly

### Parts List

Item No.	Quantity	Part No.	Description
1	1	14884	Back Plate
	1	11209	Back Plate - Slant Front (not shown)
	1	15156	Back Plate - SVO (not shown)
2	1		Timer - 3200 7 Day - 3200 12 Day - 3210 Meter
3	1	11838	Power Cord
4	1	13547	Strain Relief
5	1	11667	Wire Harness
7	5	10872	Screw - Motor Mounting
8			Not Assigned
9			Not Assigned
10	1	10774	Bracket - Motor Mounting
11	2	10231	Screw - Drive Mounting
12	2	10302	Insulator
13	2	10218	Switch
14	1	10909	Connecting Link Pin
15	3	10250	Retaining Ring
16	1	10621	Connecting Link
17	1	12102	Drive Cam - RR
	1	12576	Drive Cam - STF
18	2	10338	Roll Pin
19	1	13366	Drive Bearing
20	2	14923	Screw - Switch Mounting
21	1	10769	Motor
22	1	11826	Bracket - Brine Valve Side
23	1	12777	Brine Valve Cam - STF
	1	10815	Brine Valve Cam - RR (not shown)
	1	12472	Brine Valve Cam - SVO (not shown) - TRI
24	1	15441	Meter Cable Guide Assembly
25	1	15513	Meter Cable Assembly
26	2	10300	Screw - Timer Mounting (not shown)
27	2	15742	Screw (not shown)
28	2	15833	Spacer, Cover (not shown)
29	1	19291-020	Cover, 1 Piece, Black (not shown)
30	2	19367	Screw, Cover (not shown)

# MODEL 2750 DOWNFLOW

## Control Valve with 1700 Injector

(see opposite page for parts list)

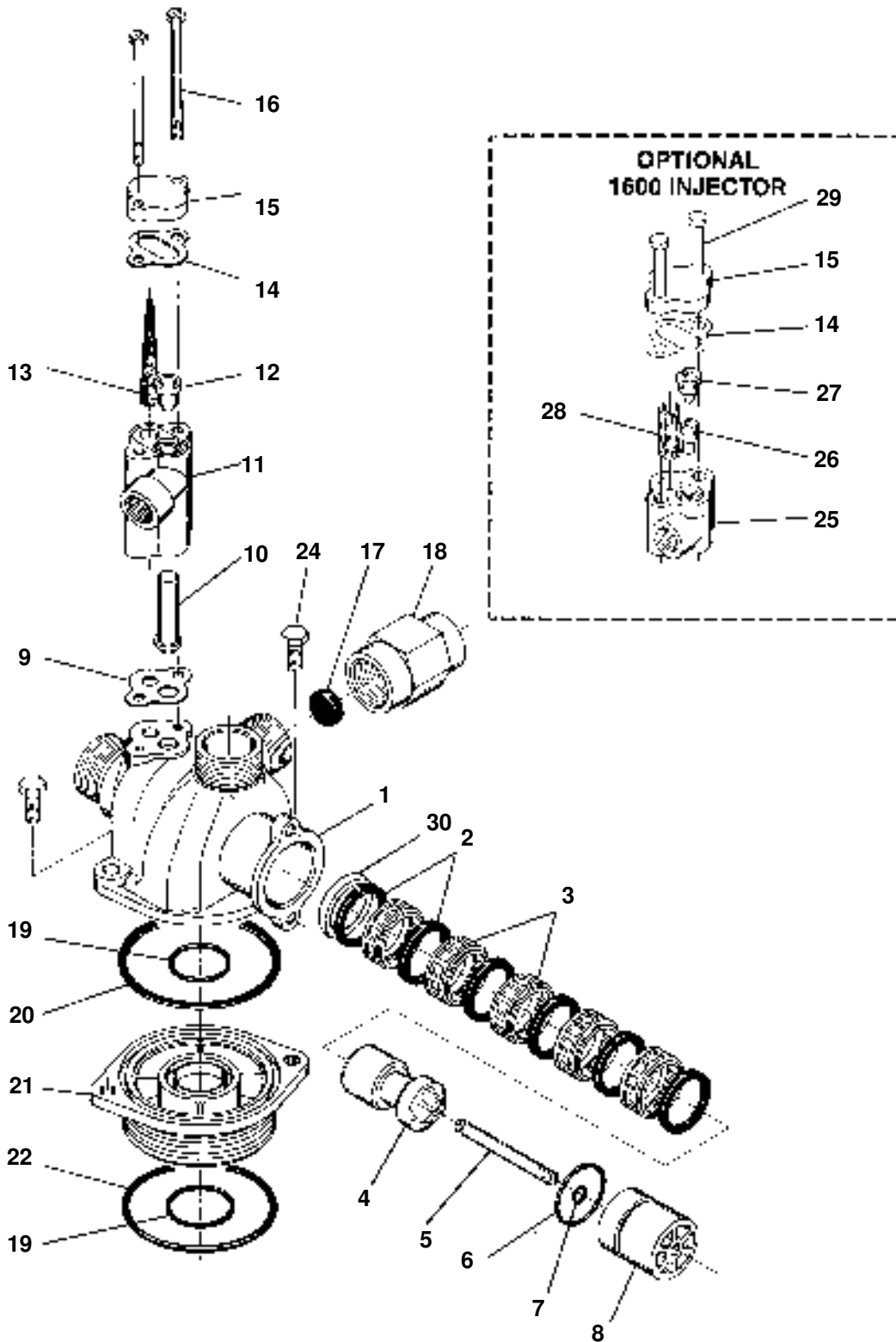



# MODEL 2750 DOWNFLOW

---

## *Control Valve*

---

### *Parts List*

---

<b>Item No.</b>	<b>Quantity</b>	<b>Part No.</b>	<b>Description</b>
1	1	14749	Valve Body
2	6	10545	Seal
3	5	11451	Spacer
		16589	Spacer, Hot Water
4	1	14451	Piston
5	1	14452	Piston Rod
6	1	10234	O-Ring - End Plug
7	1	10209	Quad Ring - Piston Rod
8	1	10598	End Plug Assembly
		10598-01	End Plug Assembly, Hot Water
9	1	14805	Injector Body Gasket
10	1	14802	Injector Throat
11	1	17777	Injector Body
12	1	14801	Injector Nozzle
13	1	14803	Injector Screen
14	1	10229	Injector Cover Gasket
15	1	11893	Injector Cover
		10228	Injector Cover, Hot Water
16	2	14804	Screw - Injector Body
17	1		Washer - Flow Control (specify size)
18	1	15177	Flow Control Housing
19	2	11710	O-Ring Base
20	1	11208	O-Ring Base
21	1	12461	Adapter Base 2-1/2-8 Thd
22	1	10381	O-Ring - Top of Tank
24	2	11224	Screw - Valve Mounting
25	1	17776	Injector Body
26	1	10914	Injector Throat
27	1	10913	Injector Nozzle
28	1	10227	Injector Screen
29	2	10692	Screw - Injector Body
30	1	10757	End Spacer
		10757B	End Spacer, Hot Water
31	1	16221	Air Disperser - 1600 Injector (not shown)

# MODEL 2750 DOWNFLOW

## 1600 Series Brine System Assembly

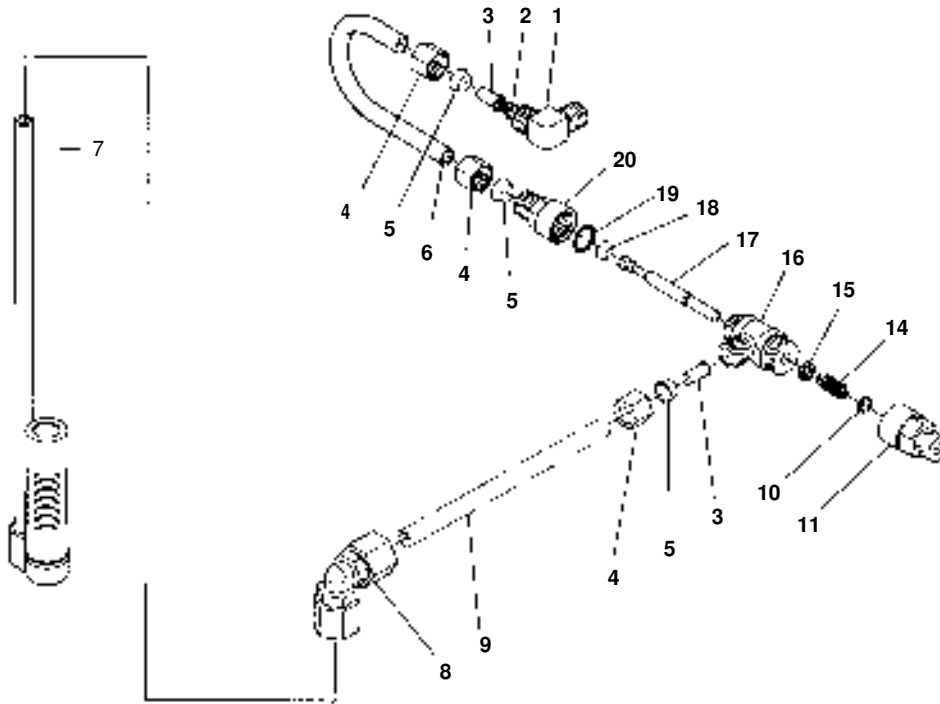

### PARTS LIST

Item No.	Quantity	Part No.	Description
1	1	10328	90° Elbow - 1/4" Pipe Thd. to 3/8" Tube
2	1	12767	Brine Line Screen
3	2	10332	Insert Sleeve (3/8" Tube)
4	3	10329	Fitting Nut (3/8" Tube)
5	3	10330	Derlin Sleeve (3/8" Tube)
6	1	15221	Brine Valve Tube
7	1	60002	#500 Air Check Assembly
		60003	#500 Air Check Assembly, Hot Water
8	1	12794	90° Elbow - 3/8" Tube to 3/8" Tube
9	1	Not Supplied	Brine Line Tube (3/8" Flexible Tube)
10	1	10250	Retaining Ring
11	1	11749	Stem Guide
12			Not Assigned
13			Not Assigned
14	1	10249	Brine Valve Spring
15	1	12550	Quad Ring
16	1	12748	Brine Valve Body
17	1	12552	Brine Valve Stem
18	1	12626	Brine Valve Seat
19	1	11982	O-Ring
20	1	60020-25	BLFC .25 GPM
		60020-50	BLFC .50 GPM
		60020-100	BLFC 1.0 GPM

# MODEL 2750

## 1700 Series Brine System

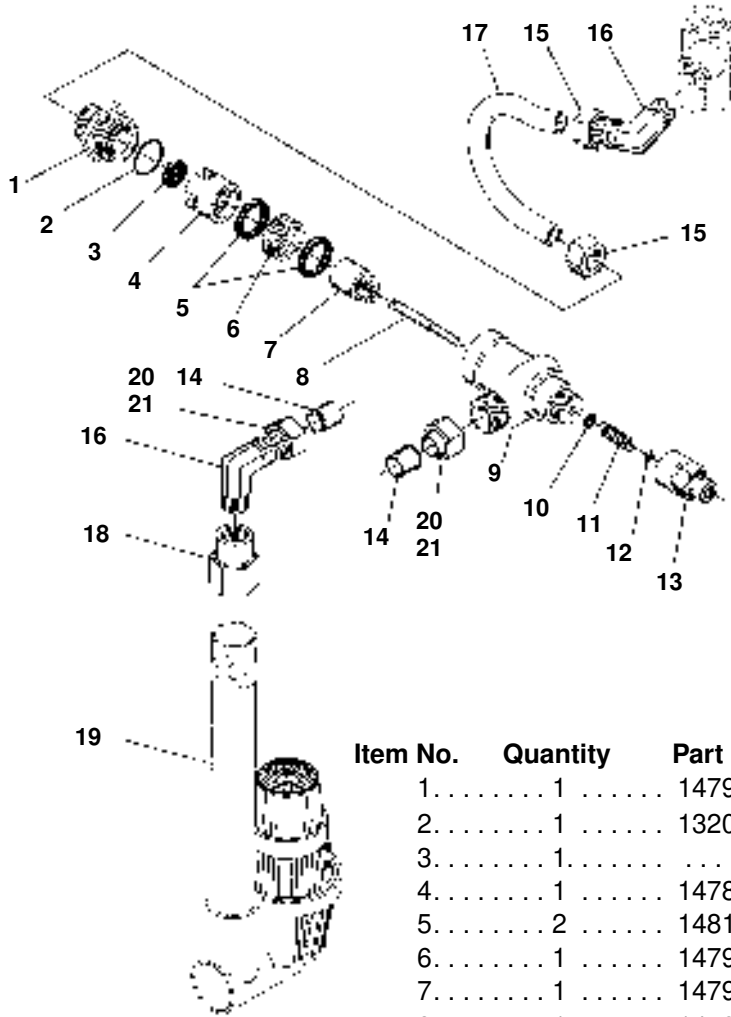

### PARTS LIST

Item No.	Quantity	Part No.	Description
1.....	1	14792	End Plug
2.....	1	13201	O-Ring - End Plug
3.....	1		Washer Flow Control (specify size)
4.....	1	14785	Flow Control Retainer
5.....	2	14811	Piston Seals
6.....	1	14798	Spacer
7.....	1	14795	Brine Valve Piston
8.....	1	14797	Brine Valve Stem
9.....	1	14790	Brine Valve Body
10.....	1	12550	Quad Ring - Brine Stem
11.....	1	15310	Spring - Brine Valve
12.....	1	10250	Retaining Ring
13.....	1	15517	Stem Guide
14.....	2	15415	Insert
15.....	2	15414	Nut & Sleeve
16.....	2	15413	Elbow
17.....	1	15416	Brine Tube
18.....	1	16977	Reducer Coupling, 1/2" NPT to 1/8" NPT
19.....	1	60009	#900 Air Check Assembly
		60009-01	#900 Air Check Assembly, Hot Water
20.....	2	16123	Nut
21.....	2	16124	Sleeve

# MODEL 2750 DOWNFLOW

## Service Valve Operator

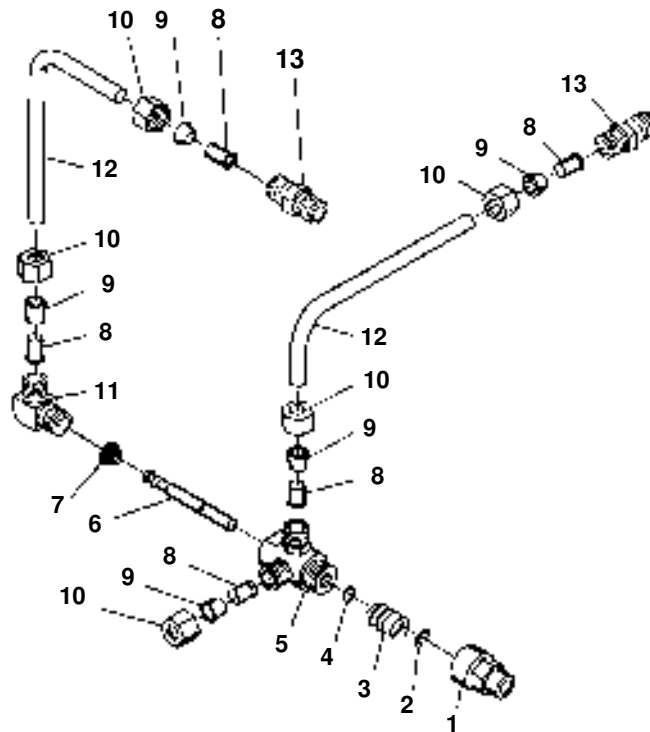

### PARTS LIST

Item No.	Quantity	Part No.	Description
1	1	11749	Guide, Brine Valve Stem
2	1	10250	Retaining Ring
3	1	10249	Spring, Brine Valve
4	1	12550	Quad Ring
5	1	10785	Service Actuator Assembly - .25 gpm
6	1	12552	Brine Valve Stem, 1600
7	1	12626	Seat, Brine Valve
8	5	10332	Insert,
9	5	10330	Sleeve, 3/8" Delrin
10	5	10329	Nut, 3/8" Brass
11	1	10328	Elbow, 90° 1/4" NPT x 3/8"
12	2	12897	Tube
13	2	16730	Connector, Male 1/8" NPT to 3/8" T

# MODEL 2750 ECONOMINDER®

## 1" Meter Assembly

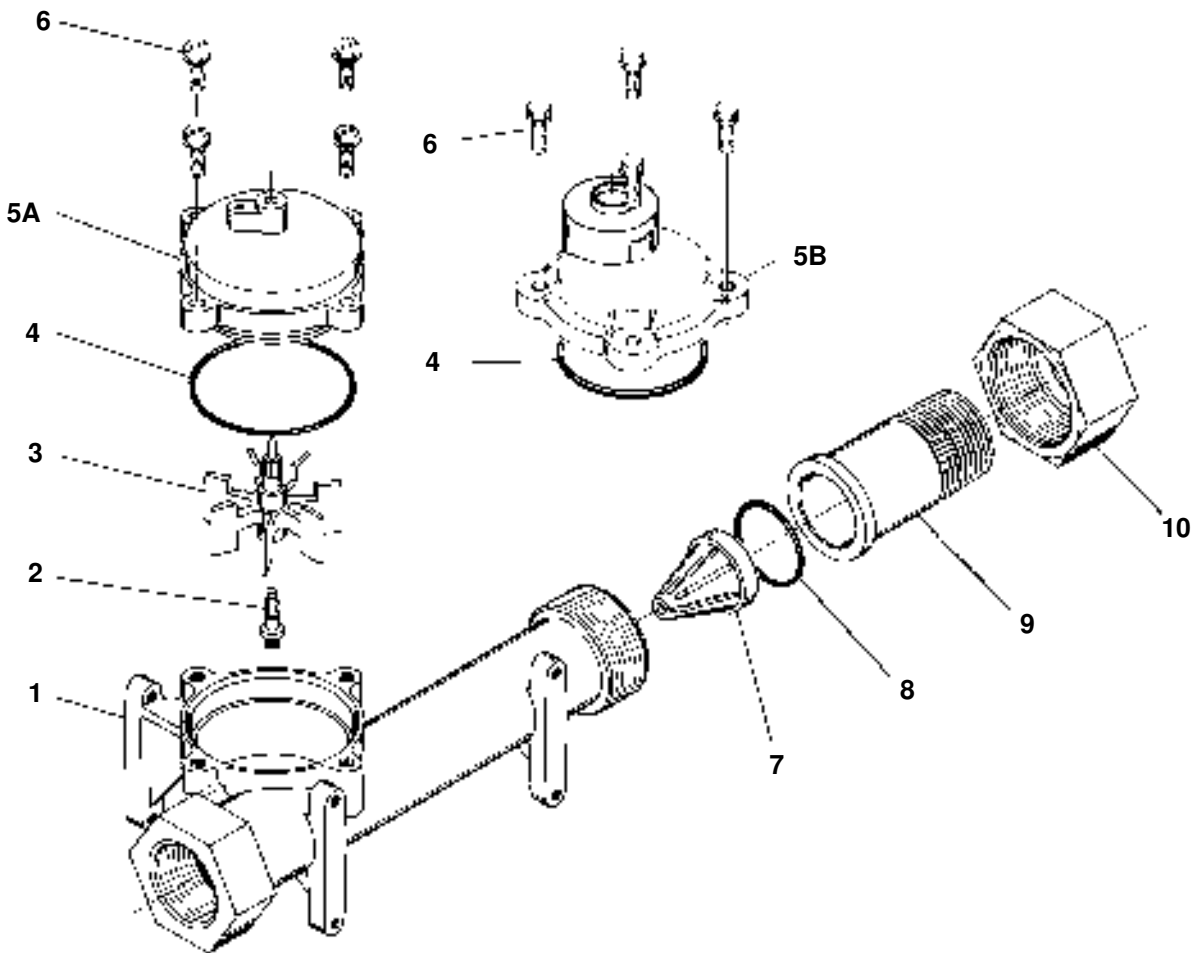

### PARTS LIST

Item No.	Quantity	Part No.	Description
1	1	14959	Meter Body
2	1	13882	Post, Meter Impeller
3	1	13509	Impeller
4	1	13847	O-Ring - Meter Cover
5A	1	15218	Meter Cover Assembly (Std.)
5B	1	15237	Meter Cover Assembly (Extended Range)
6	4	12112	Screw - Meter Cover
7	1	14960	Flow Straightener
8	1	13287	O-Ring - Quick Connect
9	1	14961	Nipple - Quick Connect
10	1	14962	Nut - Quick Connect
11	1	15308	Brass 1" Coupling (not shown)

# MODEL 2750 ECONOMINDER®

## Timer Assembly

(see opposite page for parts list)

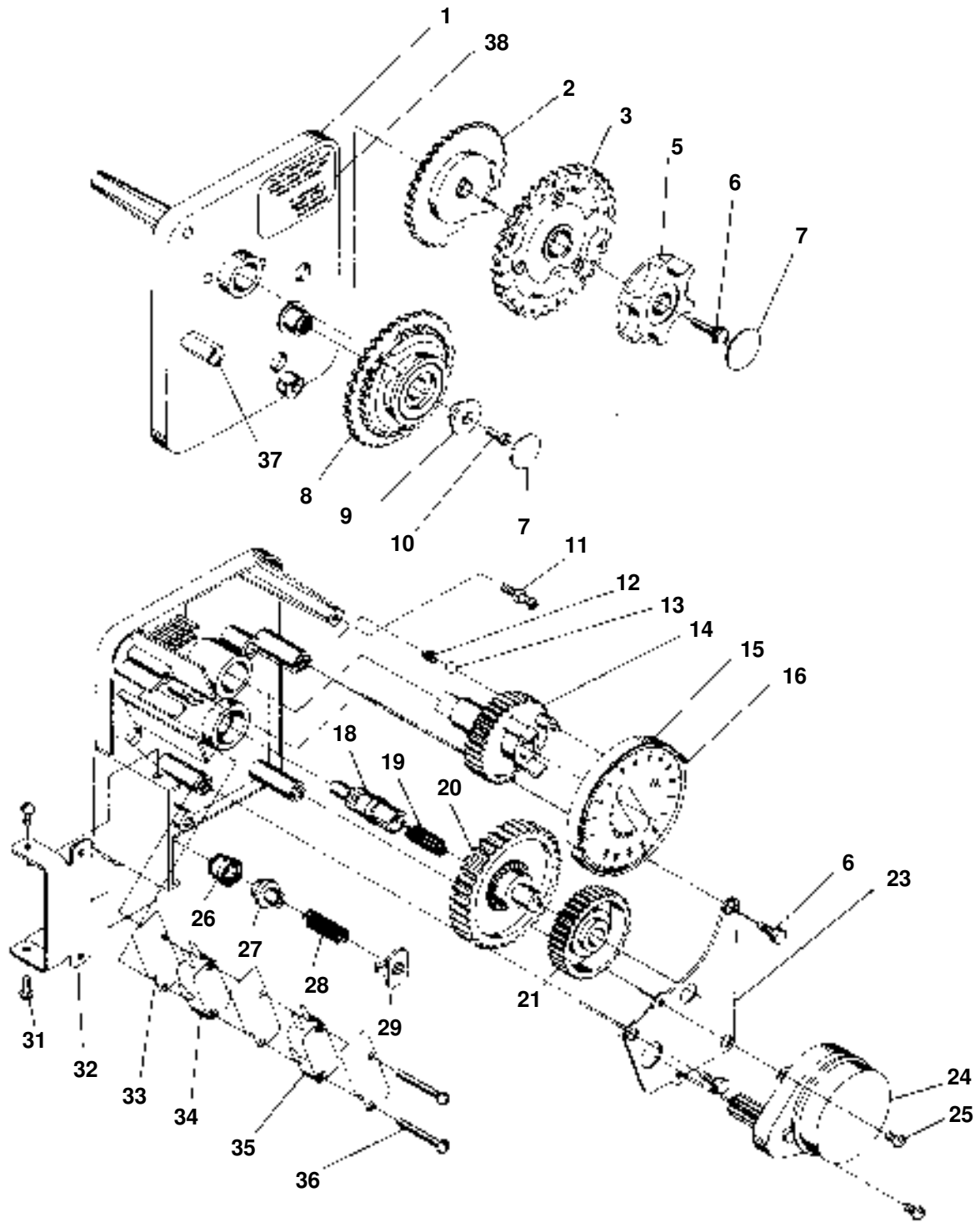

# MODEL 2750 ECONOMINDER®

## Timer Assembly

### Parts List

Item No.	Quantity	Part No.	Description
1	1	13708-01	Timer Housing Assembly
2	1	13802	Cycle Actuator Gear
3	1	40096-24	24 Hour Gear Assembly, 12 Midnight
		40096-02	24 Hour Gear Assembly, 2 AM
5	1	13886-01	Knob
6	4	13296	Screw - Timer Knob & Motor Plate Mtg.
7	2	11999	Button Decal
8	1	60405-30	Program Wheel Assembly
9	1	13806	Program Wheel Retainer
10	1	13748	Screw - Program Wheel Mtg.
11	1	14265	Spring Clip
12	1	15424	Spring - Detent
13	1	15066	Ball -1/4 in.dia.
14	1	13911	Main Drive Gear
15	1	19210	Program Wheel
16	21	15493	Roll Pin
18	1	13018	Idler Shaft
19	1	13312	Spring - Idler
20	1	13017	Idler Gear
21	1	13164	Drive Gear
23	1	13887	Motor Mounting Plate
24	1	18743	Motor - 110 V., 60Hz.
		19659	Motor - 24V., 60 Hz.
25	3	13278	Screw - Motor Mounting & Ground Wire
26	1	13830	Drive Pinion - Program Wheel
27	1	13831	Clutch - Drive Pinion
28	1	14276	Spring
29	1	14253	Spring Retainer
30			Not Assigned
31	2	11384	Screw-Timer Hinge
32	1	13881	Hinge Bracket
33	3	14087	Insulator
34	1	10896	Switch
35	1	15320	Switch
36	2	11413	Screw - Switch Mounting
37	1	14007	Decal - Time of Day
38	1	14045	Decal - Instructions
39	1	13902	Harness - Not Shown
40	2	12681	Wire Connector - Not Shown
41	1	15354-01	Ground Wire - Not Shown

# MODEL 2750 ECONOMINDER®

## 1" Commercial Demand Regeneration Control

### Timer Settings

#### Typical Programming Procedure

Calculate the gallon capacity of the system, subtract the necessary reserve requirement and set the appropriate gallons available opposite the small white dot on the program wheel gear. Note, drawing shows 10,000 gallons setting. The capacity (gallons) arrow denotes remaining gallons exclusive of calculated reserve.

#### How To Set The Time Of Day:

Press and hold the red button in to disengage the drive gear.

Turn the large gear until the actual time of day is opposite the time of day pointer.

Release the red button to again engage the drive gear.

#### How To Manually Regenerate Your Water Conditioner At Any Time.

Turn the manual regeneration knob clockwise.

This slight movement of the manual regeneration knob engages the program wheel and starts the regeneration program.

The black center knob will make one revolution in the following approximately three hours and stop in the position shown in the drawing.

Even though it takes three hours for this center knob to complete one revolution, the regeneration cycle of your unit might be set for only one half of this time.

In any event, conditioned water may be drawn after rinse water stops flowing from the water conditioner drain line.

#### Immediate Regeneration Timers:

These timers do not have a 24 hour gear. Setting the gallons on the program wheel and manual regeneration procedure are the same as previous instructions.

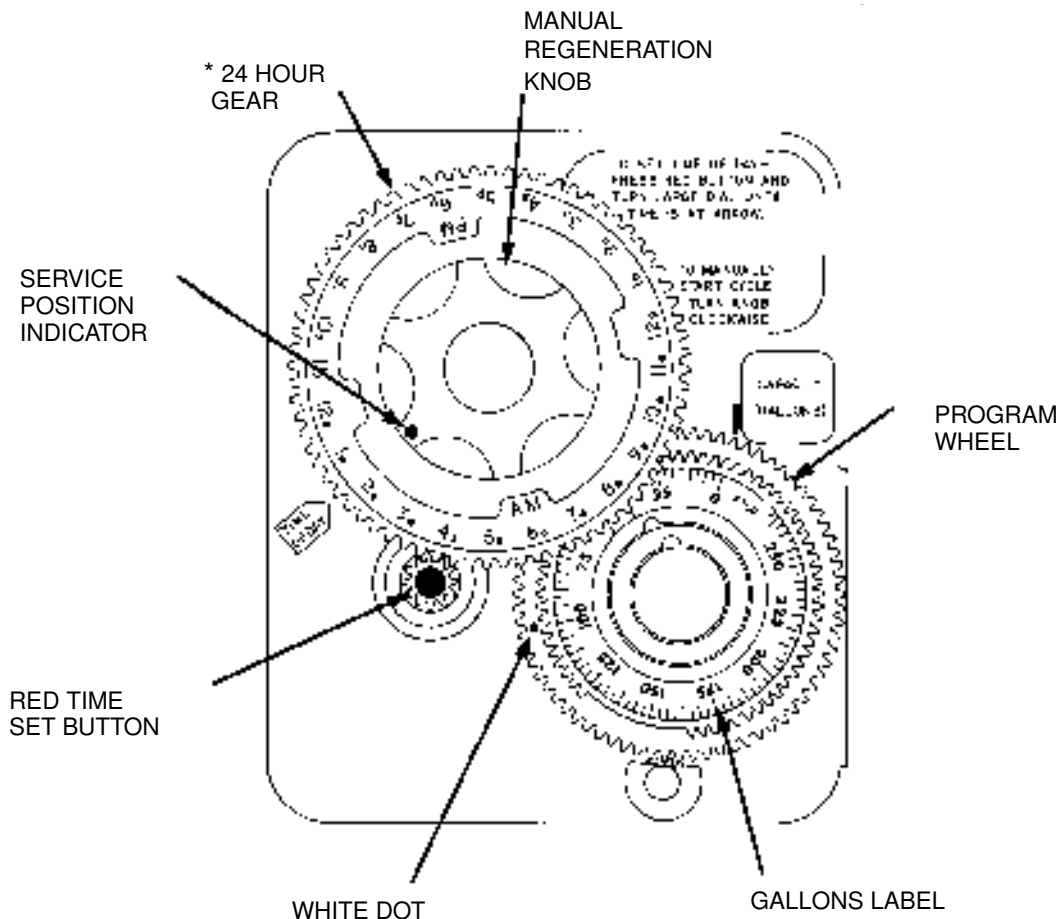

\* Immediate regeneration times do not have 24 hour gear. No time of day can be set.



# MODEL 3200 TIMER

## Timer Setting Procedure

### How To Set Days On Which Water Conditioner Is To Regenerate:

Rotate the skipper wheel until the number "1" is at the red pointer. Set the days that regeneration is to occur by sliding tabs on the skipper wheel outward to expose trip fingers. Each tab is one day. Finger at red pointer is tonight. Moving clockwise from the red pointer, extend or retract fingers to obtain the desired regeneration schedule.

### How To Set The Time of Day:

Press and hold the red button in to disengage the drive gear.

Turn the large gear until the actual time of day is at the time of day pointer.

Release the red button to again engage the drive gear.

### How To Manually Regenerate Your Water Conditioner At Any Time:

Turn the manual regeneration knob clockwise.

This slight movement of the manual regeneration knob engages the program wheel and starts the regeneration program.

The black center knob will make one revolution in the following approximately three hours and stop in the position shown in the drawing.

Even though it takes three hours for this center knob to complete one revolution, the regeneration cycle of your unit might be set only one half of this time.

In any event, conditioned water may be drawn after rinse water stops flowing from the water conditioner drain line.

### How to Adjust Regeneration Time:

1. Disconnect the power source.
2. Locate the three screws behind the manual regeneration knob by pushing the red button in and rotating the 24 hour dial until each screw appears in the cut out portion of the manual regeneration knob.
3. Loosen each screw slightly to release the pressure on the time plate from the 24 hour gear.
4. Locate the regeneration time pointer on the inside of the 24 hour dial in the cut out.
5. Turn the time plate so the desired regeneration time aligns next to the raised arrow.
6. Push the red button in and rotate the 24 hour dial. Tighten each of the three screws.
7. Push the red button and locate the pointer one more time to ensure the desired regeneration time is correct.
8. Reset the time of day and restore power to the unit.

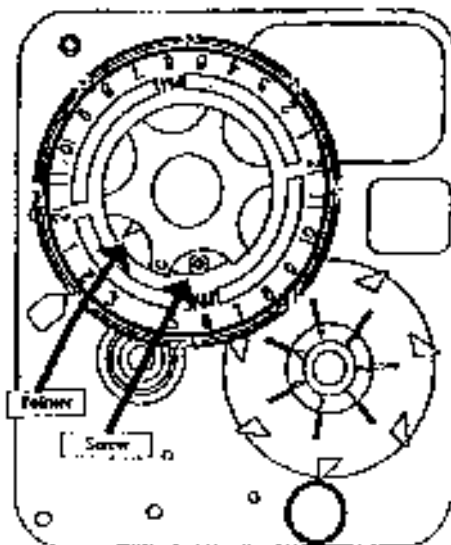
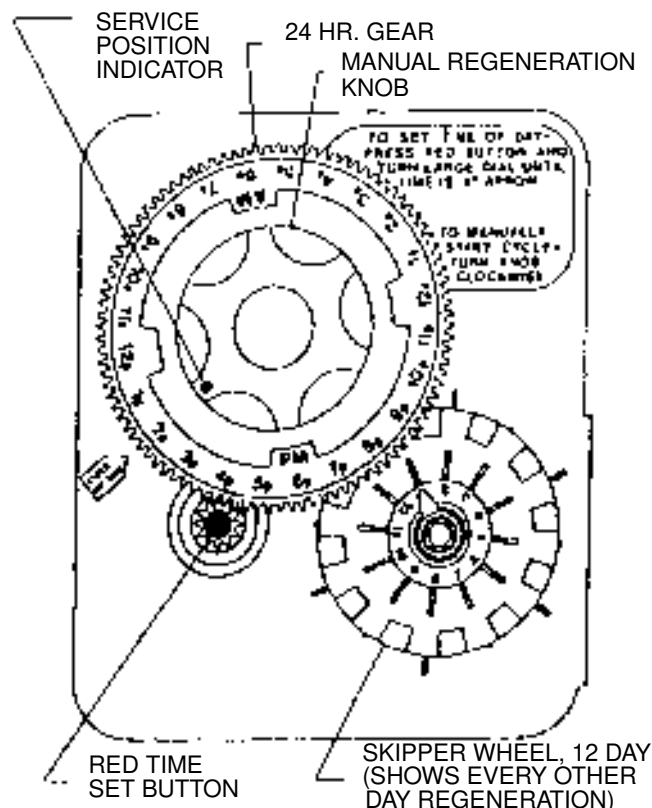

3200 ADJUSTABLE REGENERATION TIMER

### IMPORTANT!

SALT LEVEL MUST ALWAYS BE ABOVE WATER LEVEL IN BRINE TANK.

# MODEL 3200 & 3210 Timer Series

## Regenerating Cycle Program Setting Procedure

### (Brine Tank Refill Separate from Rapid Rinse)

#### How To Set The Regeneration Cycle Program:

The regeneration cycle program on your water conditioner has been factory preset, however, portions of the cycle or program may be lengthened or shortened in time to suit local conditions.

#### 3200 & 3210 Series Timers (Figure to Right)

To expose cycle program wheel, grasp timer in upper left-hand corner and pull, releasing snap retainer and swinging timer to the right.

To change the regeneration cycle program, the program wheel must be removed. Grasp program wheel and squeeze protruding lugs toward center, lift program wheel off timer. (Switch arms may require movement to facilitate removal.)

Return timer to closed position engaging snap retainer in back plate. Make certain all electrical wires locate above snap retainer post.

#### Timer Setting Procedure for 3200 & 3210 Timer

##### How To Change The Length Of The Backwash Time:

The program wheel as shown in the drawing is in the service position. As you look at the numbered side of the program wheel, the group of pins starting at zero determines the length of time your unit will backwash.

FOR EXAMPLE: If there are six pins in this section, the time of backwash will be 12 min. (2min. per pin). To change the length of backwash time, add or remove pins as required. The number of pins times two equals the backwash time in minutes.

##### How To Change The Length Of Brine And Rinse Time:

The group of holes between the last pin in the backwash section and the second group of pins determines the length of time that your unit will brine and rinse (2 min. per hole.)

To change the length of brine and rinse time, move the rapid rinse group of pins to give more or fewer holes in the brine and rinse section. Number of holes time two equals brine and rinse time in minutes.

##### How To Change The Length Of Rapid Rinse:

The second group of pins on the program wheel determines the length of time that your water conditioner will rapid rinse. (2 min. per pin.)

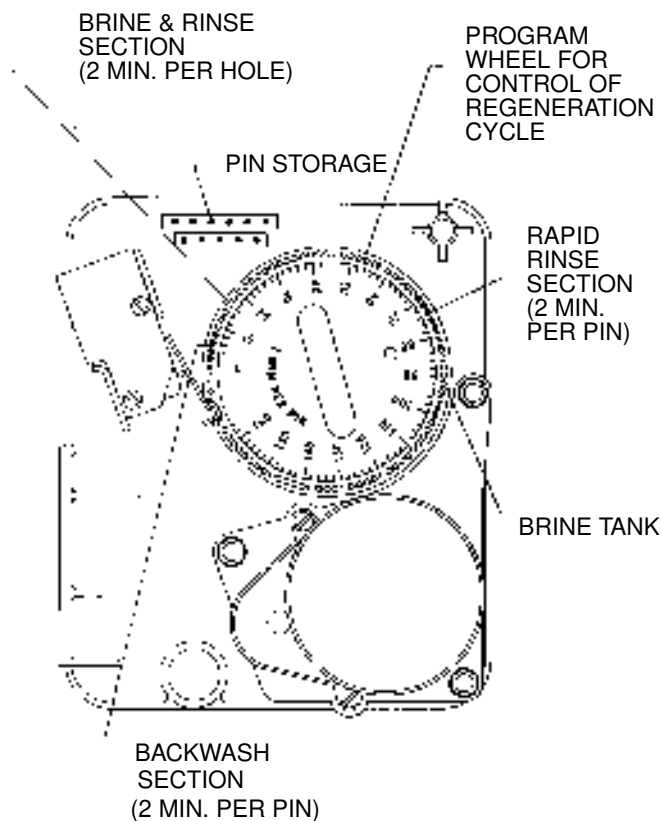

To change the length of rapid time, add or remove pins at the higher numbered end of this section as required. The number of pins times two equals the rapid rinse time in minutes.

##### How To Change The Length Of Brine Tank Refill Time:

The second group of holes in the program wheel determines the length of time that your water conditioner will refill the brine tank. (2 min. per hole.)

To change the length of refill time, move the two pins at the end of the second group of holes as required.

The regeneration cycle is complete when the outer microswitch is tripped by the two pin set at end of the brine tank refill section. The program wheel, however, will continue to rotate until the inner micro-switch drops into the notch on the program wheel.

# MODEL 2750 DOWNFLOW

## Flow Data & Injector Draw Rates

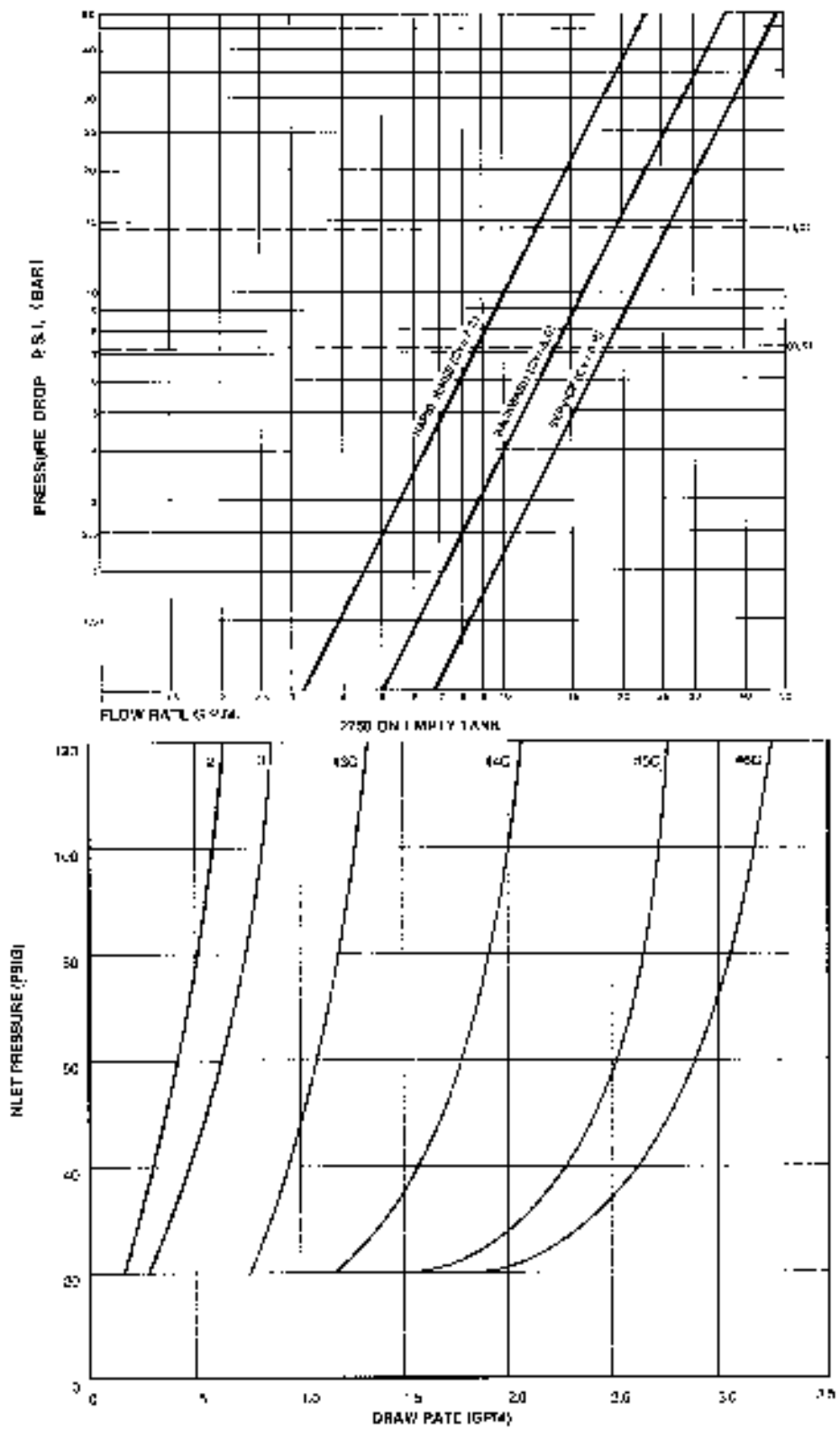

# 2750 System #4

## Valve Wiring

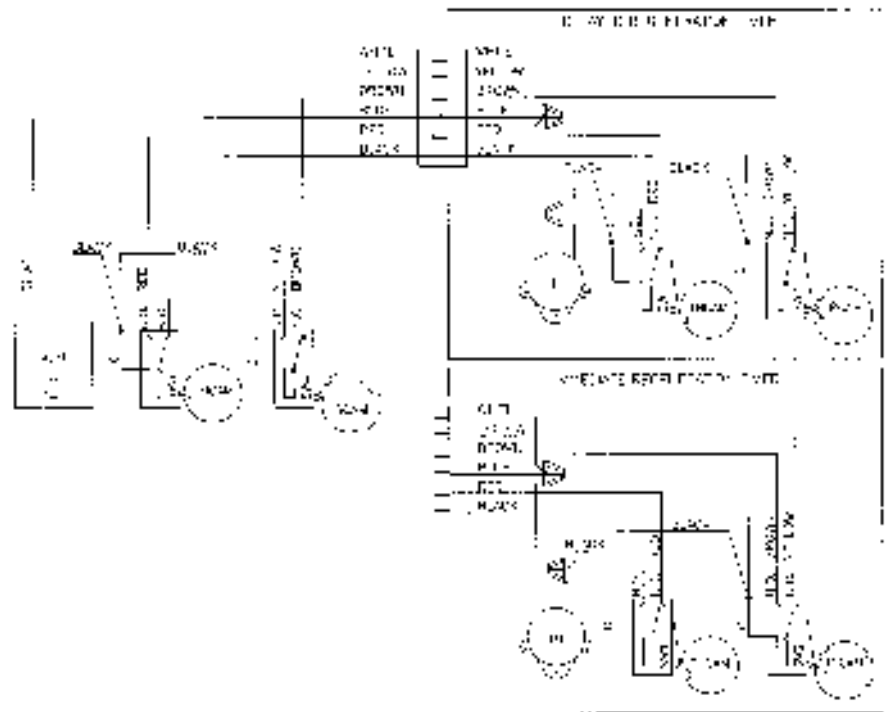

- 14 - VALVE COIL
- 15 - VALVE COIL
- 16 - VALVE COIL
- 17 - VALVE COIL
- 18 - VALVE COIL
- 19 - VALVE COIL
- 20 - VALVE COIL
- 21 - VALVE COIL
- 22 - VALVE COIL
- 23 - VALVE COIL
- 24 - VALVE COIL
- 25 - VALVE COIL
- 26 - VALVE COIL
- 27 - VALVE COIL
- 28 - VALVE COIL
- 29 - VALVE COIL
- 30 - VALVE COIL
- 31 - VALVE COIL
- 32 - VALVE COIL
- 33 - VALVE COIL
- 34 - VALVE COIL
- 35 - VALVE COIL
- 36 - VALVE COIL
- 37 - VALVE COIL
- 38 - VALVE COIL
- 39 - VALVE COIL
- 40 - VALVE COIL
- 41 - VALVE COIL
- 42 - VALVE COIL
- 43 - VALVE COIL
- 44 - VALVE COIL
- 45 - VALVE COIL
- 46 - VALVE COIL
- 47 - VALVE COIL
- 48 - VALVE COIL
- 49 - VALVE COIL
- 50 - VALVE COIL

NOTE:  
THIS WIRING DIAGRAM IS SUBJECT TO CHANGE WITHOUT NOTICE.

# 2750 System #4 With Remote Meter

## Valve Wiring

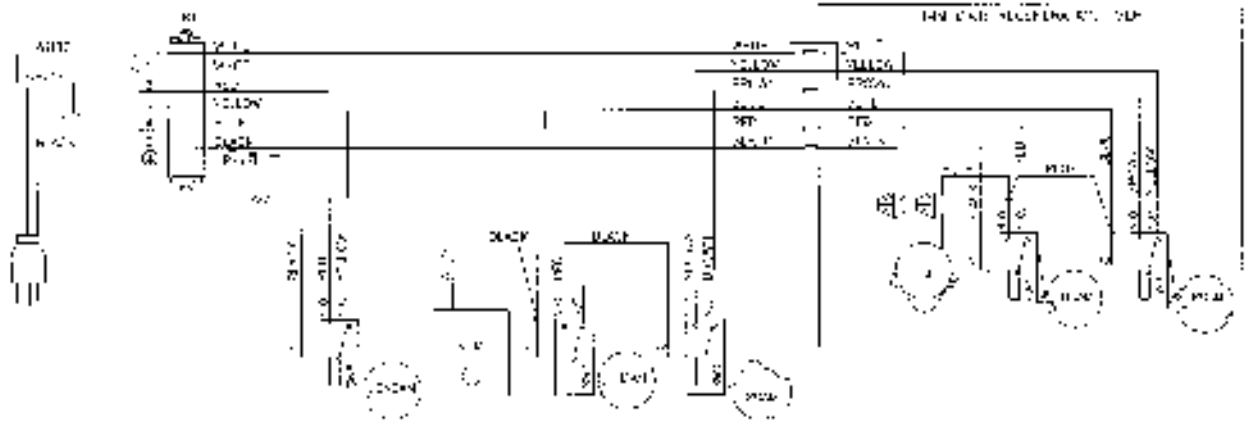

- 24VDC - 24VDC POWER
- 24VDC - 24VDC POWER
- 24VDC - 24VDC POWER
- 24VDC - 24VDC POWER
- 24VDC - 24VDC POWER
- 24VDC - 24VDC POWER
- 24VDC - 24VDC POWER
- 24VDC - 24VDC POWER
- 24VDC - 24VDC POWER
- 24VDC - 24VDC POWER
- 24VDC - 24VDC POWER
- 24VDC - 24VDC POWER
- 24VDC - 24VDC POWER
- 24VDC - 24VDC POWER
- 24VDC - 24VDC POWER

NOTE:  
 THE METER IS LOCATED IN THE RIGHT-HAND PANEL OF THE METER RACK.

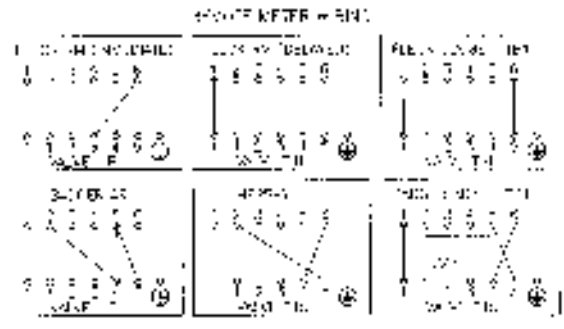

# 2750 System #5

## Valve Wiring

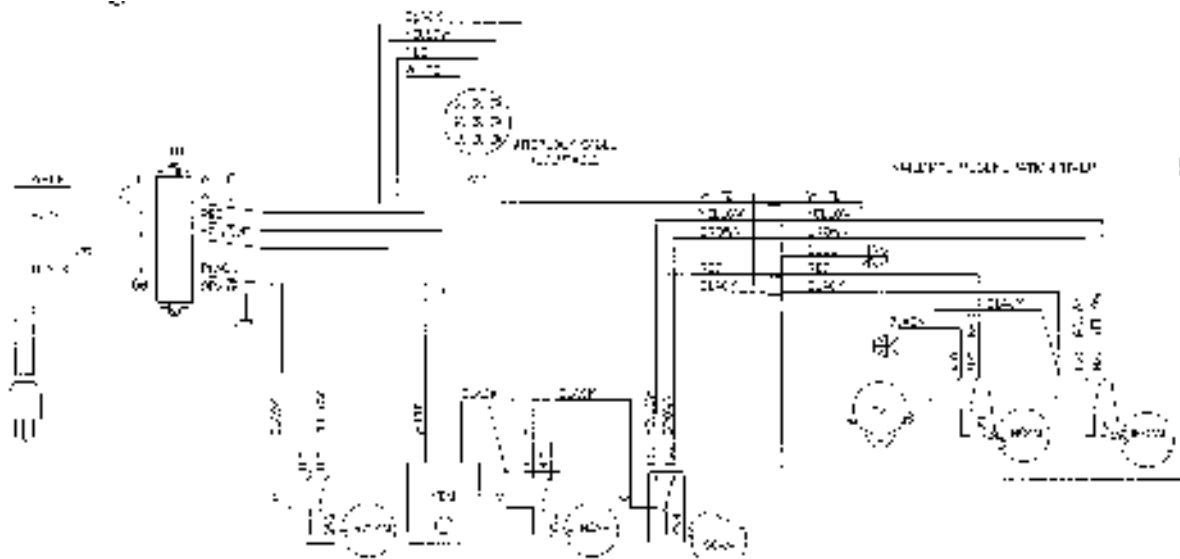

- 1 - 12VDC BATTERY
- 2 - 12VDC BATTERY
- 3 - 12VDC BATTERY
- 4 - 12VDC BATTERY
- 5 - 12VDC BATTERY
- 6 - 12VDC BATTERY
- 7 - 12VDC BATTERY
- 8 - 12VDC BATTERY
- 9 - 12VDC BATTERY
- 10 - 12VDC BATTERY
- 11 - 12VDC BATTERY
- 12 - 12VDC BATTERY
- 13 - 12VDC BATTERY
- 14 - 12VDC BATTERY
- 15 - 12VDC BATTERY
- 16 - 12VDC BATTERY
- 17 - 12VDC BATTERY
- 18 - 12VDC BATTERY
- 19 - 12VDC BATTERY
- 20 - 12VDC BATTERY

NOTE: ALL WIRING MUST BE DONE IN ACCORDANCE WITH THE WIRING MANUAL.

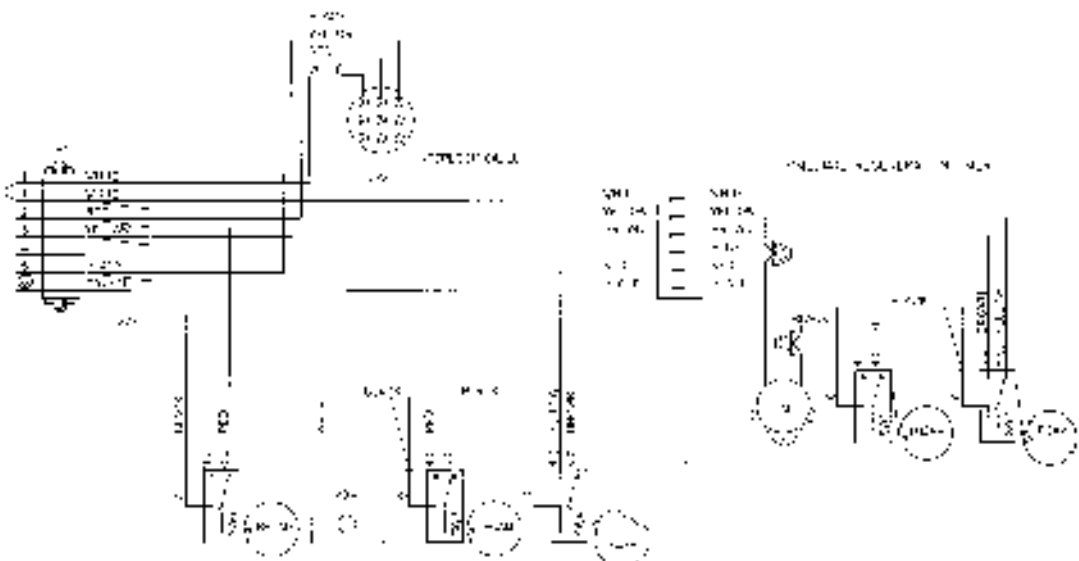

- 1 - 12VDC BATTERY
- 2 - 12VDC BATTERY
- 3 - 12VDC BATTERY
- 4 - 12VDC BATTERY
- 5 - 12VDC BATTERY
- 6 - 12VDC BATTERY
- 7 - 12VDC BATTERY
- 8 - 12VDC BATTERY
- 9 - 12VDC BATTERY
- 10 - 12VDC BATTERY
- 11 - 12VDC BATTERY
- 12 - 12VDC BATTERY
- 13 - 12VDC BATTERY
- 14 - 12VDC BATTERY
- 15 - 12VDC BATTERY
- 16 - 12VDC BATTERY
- 17 - 12VDC BATTERY
- 18 - 12VDC BATTERY
- 19 - 12VDC BATTERY
- 20 - 12VDC BATTERY

# 2750 System #6

## Valve Wiring

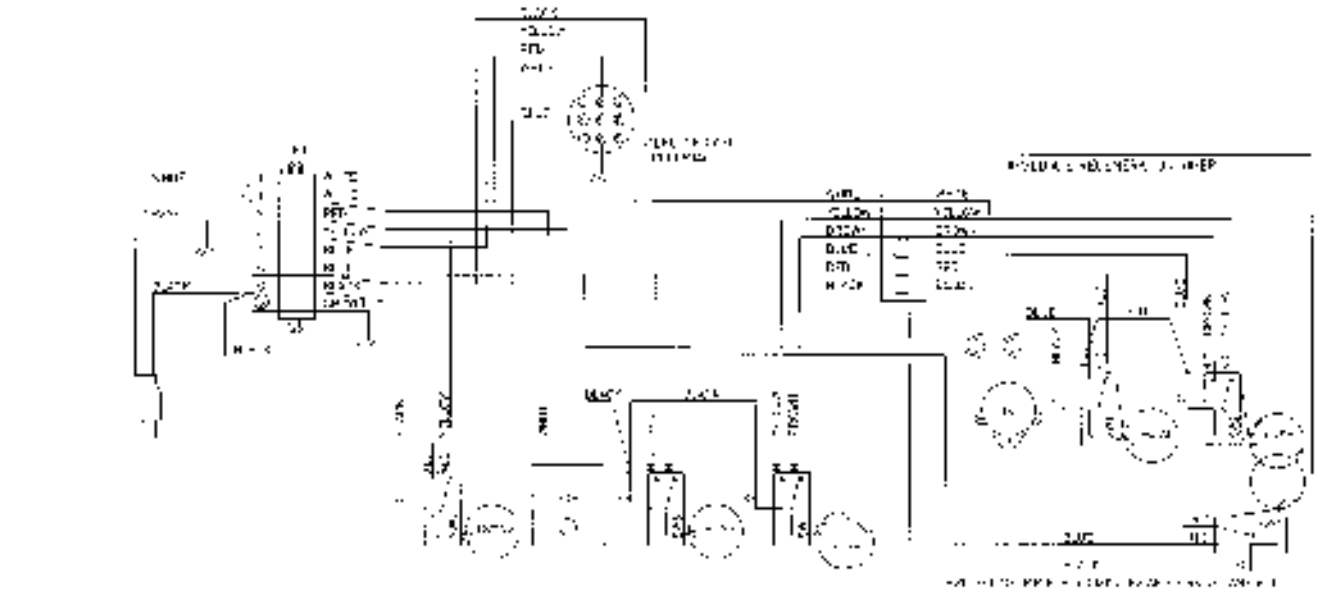

- W1 - 120V
- W2 - 120V
- W3 - 120V
- W4 - 120V
- W5 - 120V
- W6 - 120V
- W7 - 120V
- W8 - 120V
- W9 - 120V
- W10 - 120V
- W11 - 120V
- W12 - 120V
- W13 - 120V
- W14 - 120V
- W15 - 120V
- W16 - 120V
- W17 - 120V
- W18 - 120V
- W19 - 120V
- W20 - 120V

NOTE: ALL WIRING SHALL BE IN ACCORDANCE WITH THE NATIONAL ELECTRICAL CODE AND ALL LOCAL ORDINANCES THEREUNDER. THE WIRING SHALL BE IN ACCORDANCE WITH THE MANUFACTURER'S RECOMMENDATIONS.

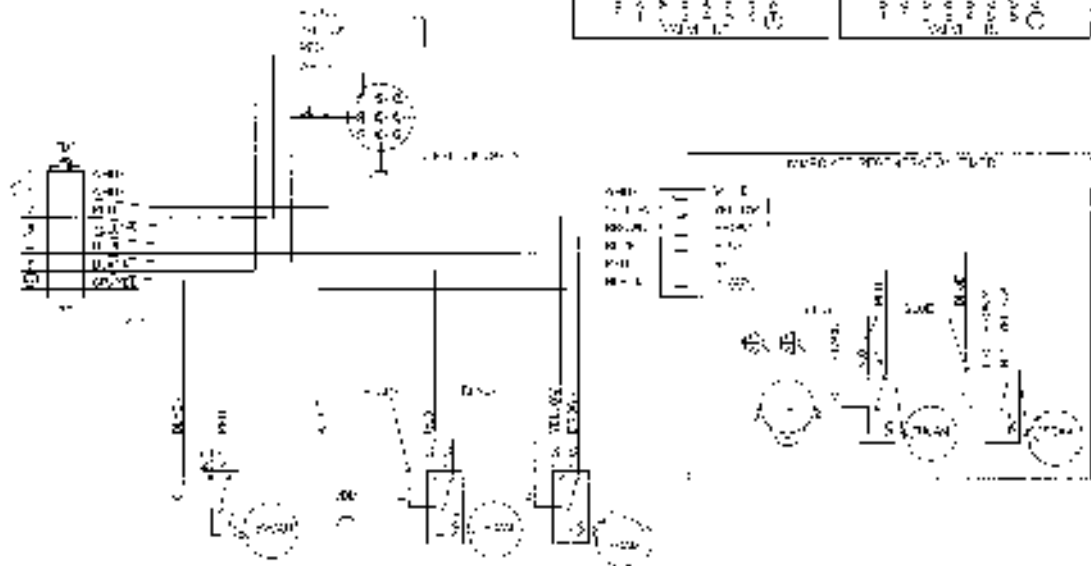
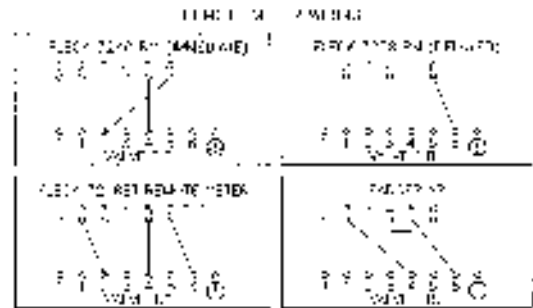

- W1 - 120V
- W2 - 120V
- W3 - 120V
- W4 - 120V
- W5 - 120V
- W6 - 120V
- W7 - 120V
- W8 - 120V
- W9 - 120V
- W10 - 120V
- W11 - 120V
- W12 - 120V
- W13 - 120V
- W14 - 120V
- W15 - 120V
- W16 - 120V
- W17 - 120V
- W18 - 120V
- W19 - 120V
- W20 - 120V

# 2750 24V/120V System #7

## Valve Wiring

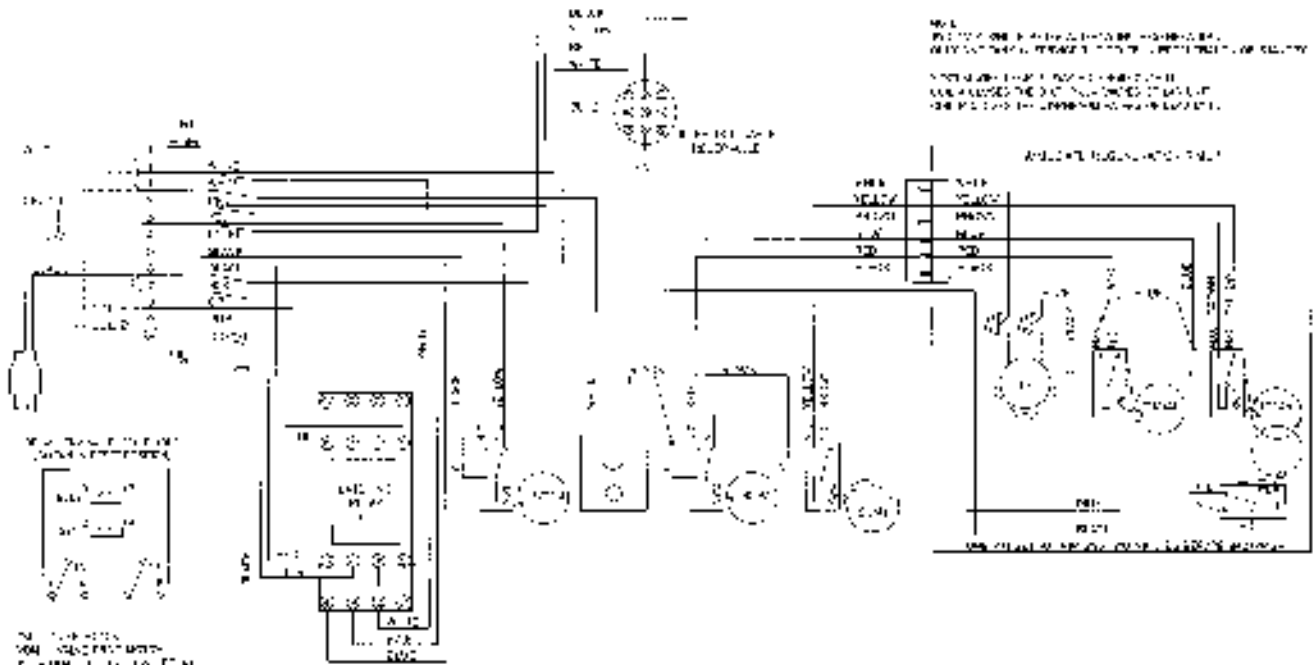

- 24 - 24VDC
- 25 - 24VDC
- 26 - 24VDC
- 27 - 24VDC
- 28 - 24VDC
- 29 - 24VDC
- 30 - 24VDC
- 31 - 24VDC
- 32 - 24VDC
- 33 - 24VDC
- 34 - 24VDC
- 35 - 24VDC
- 36 - 24VDC
- 37 - 24VDC
- 38 - 24VDC
- 39 - 24VDC
- 40 - 24VDC
- 41 - 24VDC
- 42 - 24VDC
- 43 - 24VDC
- 44 - 24VDC
- 45 - 24VDC
- 46 - 24VDC
- 47 - 24VDC
- 48 - 24VDC
- 49 - 24VDC
- 50 - 24VDC
- 51 - 24VDC
- 52 - 24VDC
- 53 - 24VDC
- 54 - 24VDC
- 55 - 24VDC
- 56 - 24VDC
- 57 - 24VDC
- 58 - 24VDC
- 59 - 24VDC
- 60 - 24VDC
- 61 - 24VDC
- 62 - 24VDC
- 63 - 24VDC
- 64 - 24VDC
- 65 - 24VDC
- 66 - 24VDC
- 67 - 24VDC
- 68 - 24VDC
- 69 - 24VDC
- 70 - 24VDC
- 71 - 24VDC
- 72 - 24VDC
- 73 - 24VDC
- 74 - 24VDC
- 75 - 24VDC
- 76 - 24VDC
- 77 - 24VDC
- 78 - 24VDC
- 79 - 24VDC
- 80 - 24VDC
- 81 - 24VDC
- 82 - 24VDC
- 83 - 24VDC
- 84 - 24VDC
- 85 - 24VDC
- 86 - 24VDC
- 87 - 24VDC
- 88 - 24VDC
- 89 - 24VDC
- 90 - 24VDC
- 91 - 24VDC
- 92 - 24VDC
- 93 - 24VDC
- 94 - 24VDC
- 95 - 24VDC
- 96 - 24VDC
- 97 - 24VDC
- 98 - 24VDC
- 99 - 24VDC
- 100 - 24VDC

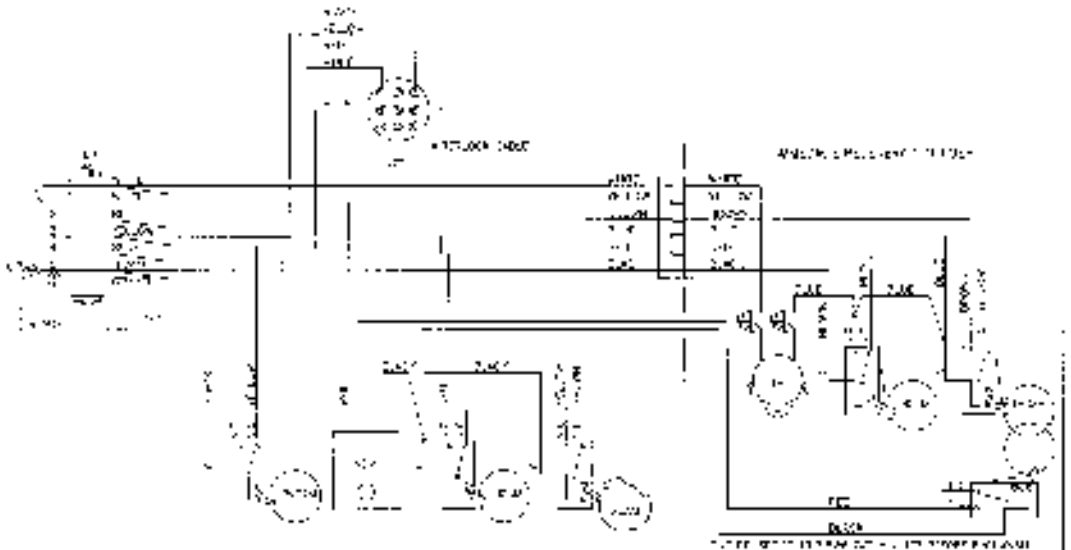
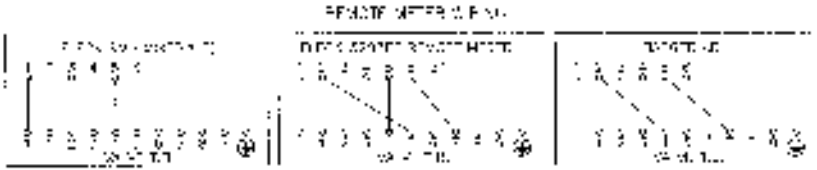

- 24 - 24VDC
- 25 - 24VDC
- 26 - 24VDC
- 27 - 24VDC
- 28 - 24VDC
- 29 - 24VDC
- 30 - 24VDC
- 31 - 24VDC
- 32 - 24VDC
- 33 - 24VDC
- 34 - 24VDC
- 35 - 24VDC
- 36 - 24VDC
- 37 - 24VDC
- 38 - 24VDC
- 39 - 24VDC
- 40 - 24VDC
- 41 - 24VDC
- 42 - 24VDC
- 43 - 24VDC
- 44 - 24VDC
- 45 - 24VDC
- 46 - 24VDC
- 47 - 24VDC
- 48 - 24VDC
- 49 - 24VDC
- 50 - 24VDC
- 51 - 24VDC
- 52 - 24VDC
- 53 - 24VDC
- 54 - 24VDC
- 55 - 24VDC
- 56 - 24VDC
- 57 - 24VDC
- 58 - 24VDC
- 59 - 24VDC
- 60 - 24VDC
- 61 - 24VDC
- 62 - 24VDC
- 63 - 24VDC
- 64 - 24VDC
- 65 - 24VDC
- 66 - 24VDC
- 67 - 24VDC
- 68 - 24VDC
- 69 - 24VDC
- 70 - 24VDC
- 71 - 24VDC
- 72 - 24VDC
- 73 - 24VDC
- 74 - 24VDC
- 75 - 24VDC
- 76 - 24VDC
- 77 - 24VDC
- 78 - 24VDC
- 79 - 24VDC
- 80 - 24VDC
- 81 - 24VDC
- 82 - 24VDC
- 83 - 24VDC
- 84 - 24VDC
- 85 - 24VDC
- 86 - 24VDC
- 87 - 24VDC
- 88 - 24VDC
- 89 - 24VDC
- 90 - 24VDC
- 91 - 24VDC
- 92 - 24VDC
- 93 - 24VDC
- 94 - 24VDC
- 95 - 24VDC
- 96 - 24VDC
- 97 - 24VDC
- 98 - 24VDC
- 99 - 24VDC
- 100 - 24VDC





# MODEL 2750 DOWNFLOW

## Service Instructions

PROBLEM	CAUSE	CORRECTION
1. Softener fails to regenerate.	A. Electrical service to unit has been interrupted. B. Timer is defective. C. Power failure.	A. Assure permanent electrical service (check fuse, plug, pull chain or switch). B. Replace timer. C. Reset time of day.
2. Hard water.	A. By-pass valve is open. B. No salt in brine tank. C. Injectors or screen plugged. D. Insufficient water flowing into brine tank. E. Hot water tank hardness. F. Leak at distributor tube. G. Internal valve leak	A. Close by-pass valve. B. Add salt to brine tank and maintain salt level above water level. C. Clean injector screen. D. Check brine tank fill time and clean brine line flow if plugged. E. Repeated flushings of the hot water tank is required. F. Make sure distributor tube is not cracked. Check O-Ring and tube pilot. G. Replace seals and spacers and/or piston.
3. Unit used too much salt.	A. Improper salt setting. B. Excessive water in brine tank.	A. Check salt usage and salt setting. B. See problem No. 7.
4. Loss of water pressure.	A. Iron buildup in line to water conditioner. B. Iron buildup in water conditioner. C. Inlet of control plugged due to foreign material broken loose from pipes by recent work done on plumbing system.	A. Clean line to water conditioner. B. Clean control and add mineral bed. Increase frequency of regeneration. C. Remove piston and clean control.
5. Loss of mineral through drain line.	A. Air in water system. B. Improper sized drain line flow control.	A. Assure that well system has proper air eliminator control check for dry well condition. B. Check for proper drain rate.
6. Iron in conditioned water.	A. Fouled mineral bed.	A. Check backwash, brine draw and brine tank fill. Increase frequency of regeneration. Increase backwash time.
7. Excessive water in brine tank.	A. Plugged drain line flow control. B. Plugged injector system. C. Timer not cycling. D. Foreign material in brine valve. E. Foreign material in brine line flow control.	A. Clean flow control. B. Clean injector and screen. C. Replace timer. D. Replace brine valve seat and clean valve. E. Clean brine line flow control.

# MODEL 2750 DOWNFLOW

## Service Instructions (Cont'd.)

PROBLEM	CAUSE	CORRECTION
8. Softener fails to draw brine	<ul style="list-style-type: none"> <li>A. Drain line flow control is plugged.</li> <li>B. Injector is plugged.</li> <li>C. Injector screen plugged.</li> <li>D. Line pressure is too low.</li> <li>E. Internal control leak.</li> <li>F. Service adapter did not cycle.</li> </ul>	<ul style="list-style-type: none"> <li>A. Clean injector and replace screen.</li> <li>B. Clean injector.</li> <li>C. Clean screen.</li> <li>D. Increase line pressure to 20 P.S.I.</li> <li>E. Change seals, spacers and piston assembly.</li> <li>F. Check drive motor and switches.</li> </ul>
9. Control cycles continuously.	<ul style="list-style-type: none"> <li>A. Missadjusted, broken or shorted switch.</li> </ul>	<ul style="list-style-type: none"> <li>A. Determine if switch or timer is faulty and replace it, or replace complete power head.</li> </ul>
10. Drain flows continuously.	<ul style="list-style-type: none"> <li>A. Valve is not programming correctly.</li> <li>B. Foreign material in control.</li> <li>C. Internal control leak.</li> </ul>	<ul style="list-style-type: none"> <li>A. Check timer program and positioning of control. Replace power head assembly if not positioning properly.</li> <li>B. Remove power head assembly and inspect bore, remove foreign material and check control in various regeneration positions.</li> <li>C. Replace seals and piston assembly.</li> </ul>

### General Service Hints For Meter Control

**Problem: Softener Delivers Hard Water.**

Cause could be that. . . Reserve Capacity Has Been Exceeded.

**Correction:** Check salt dosage requirements and reset program wheel to provide additional reserve.

Cause could be that. . . Program Wheel Is Not Rotating With Meter Output

**Correction:** Pull cable out of meter cover and rotate manually. Program wheel must move without binding and clutch must give positive "clicks" when program wheel strikes regeneration stop. If it does not, replace timer.

Cause could be that. . . Meter Is Not Measuring Flow.

**Correction:** Check meter with meter checker.

# MODEL 2750

## System #4 - Typical Single Tank Installation with Optional Meter

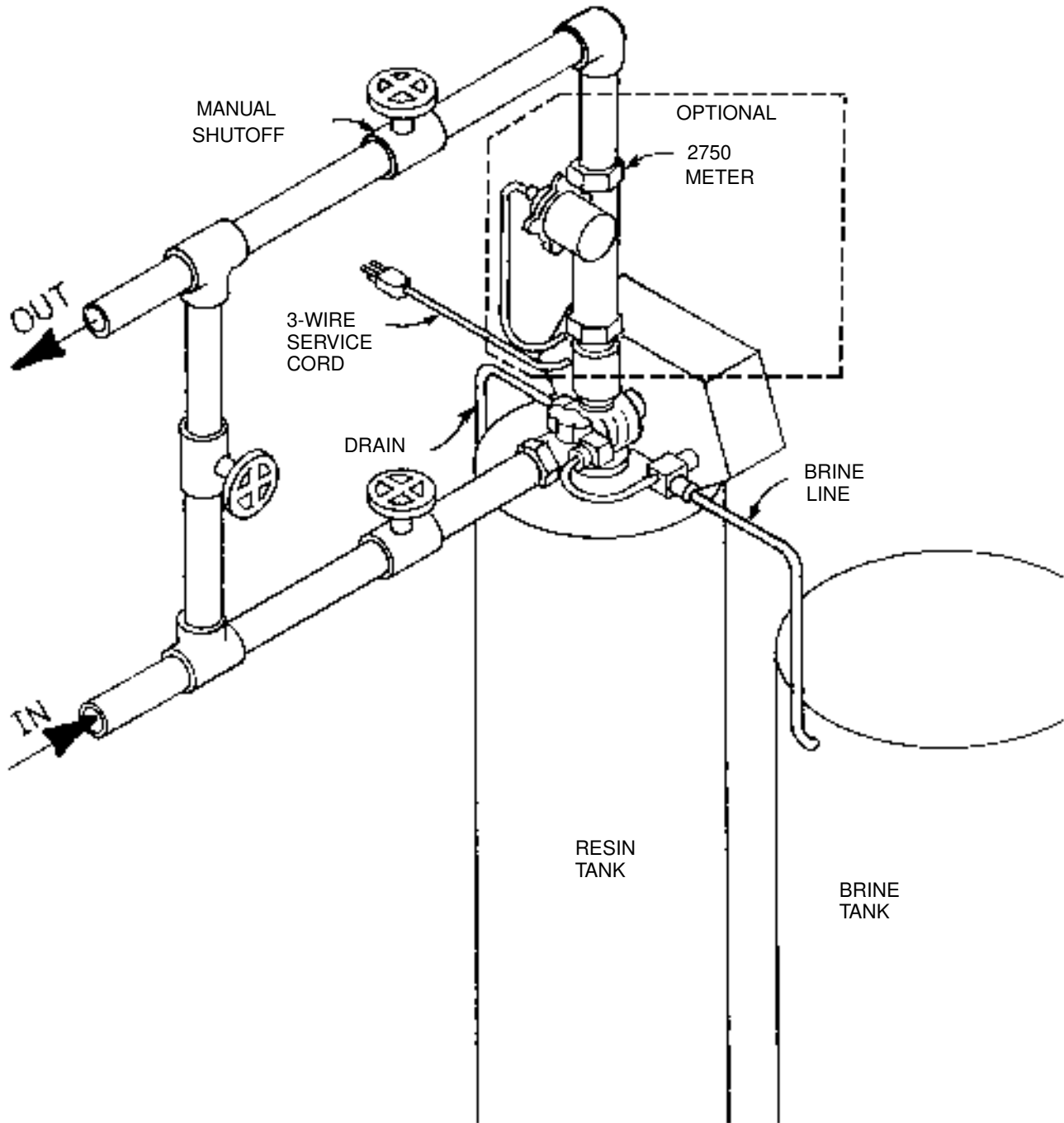

# MODEL 2750

## System #5 Interlock - Typical Twin Tank Installation with Optional 2 Meter Interlock and No Hard Water Bypass

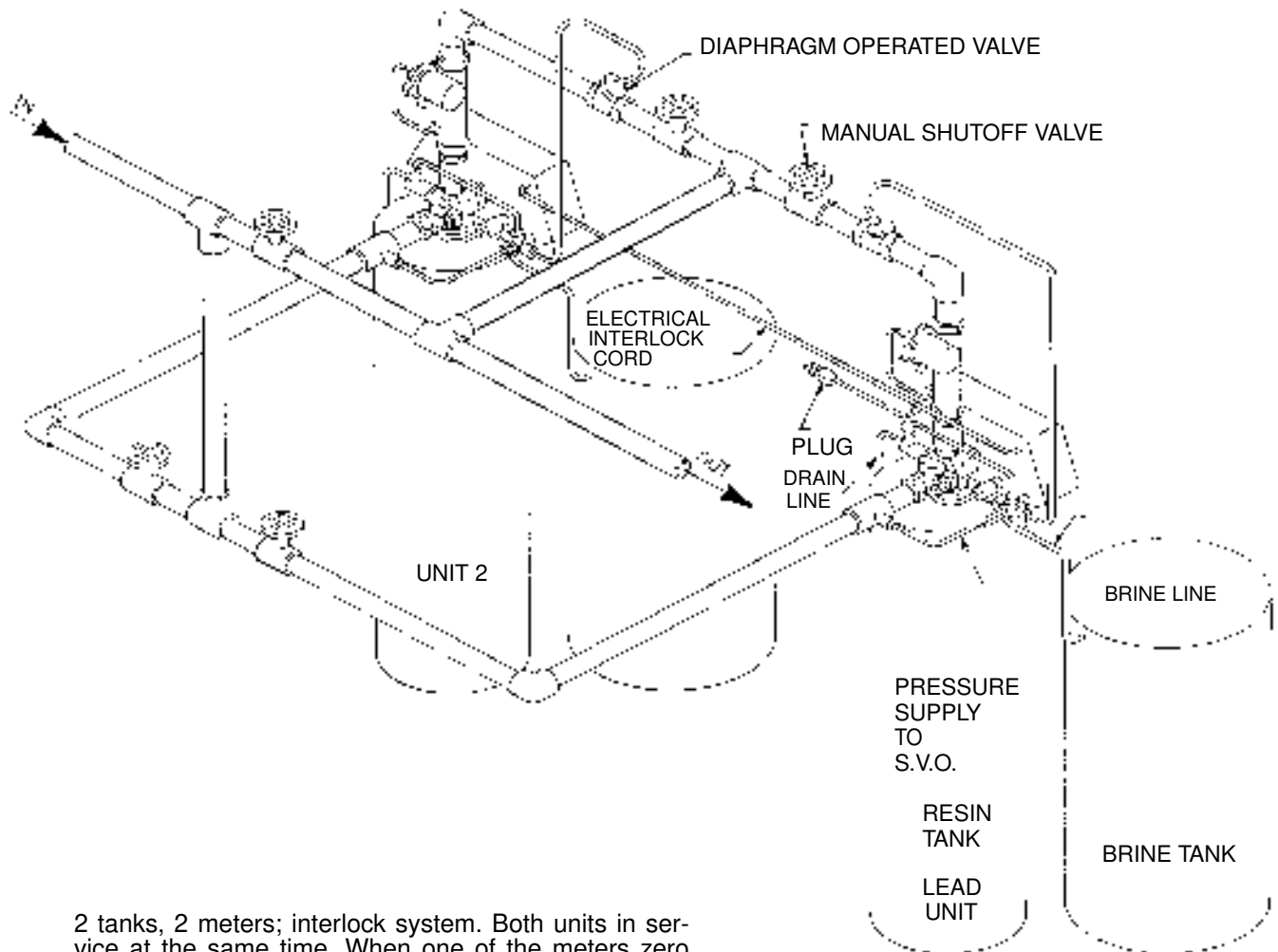

2 tanks, 2 meters; interlock system. Both units in service at the same time. When one of the meters zero out, that unit starts into a regeneration. The other unit remains in service, even if it zeros out during this time.

# MODEL 2750

## System #6 - Twin Series Regeneration

### Installation with a Remote Meter

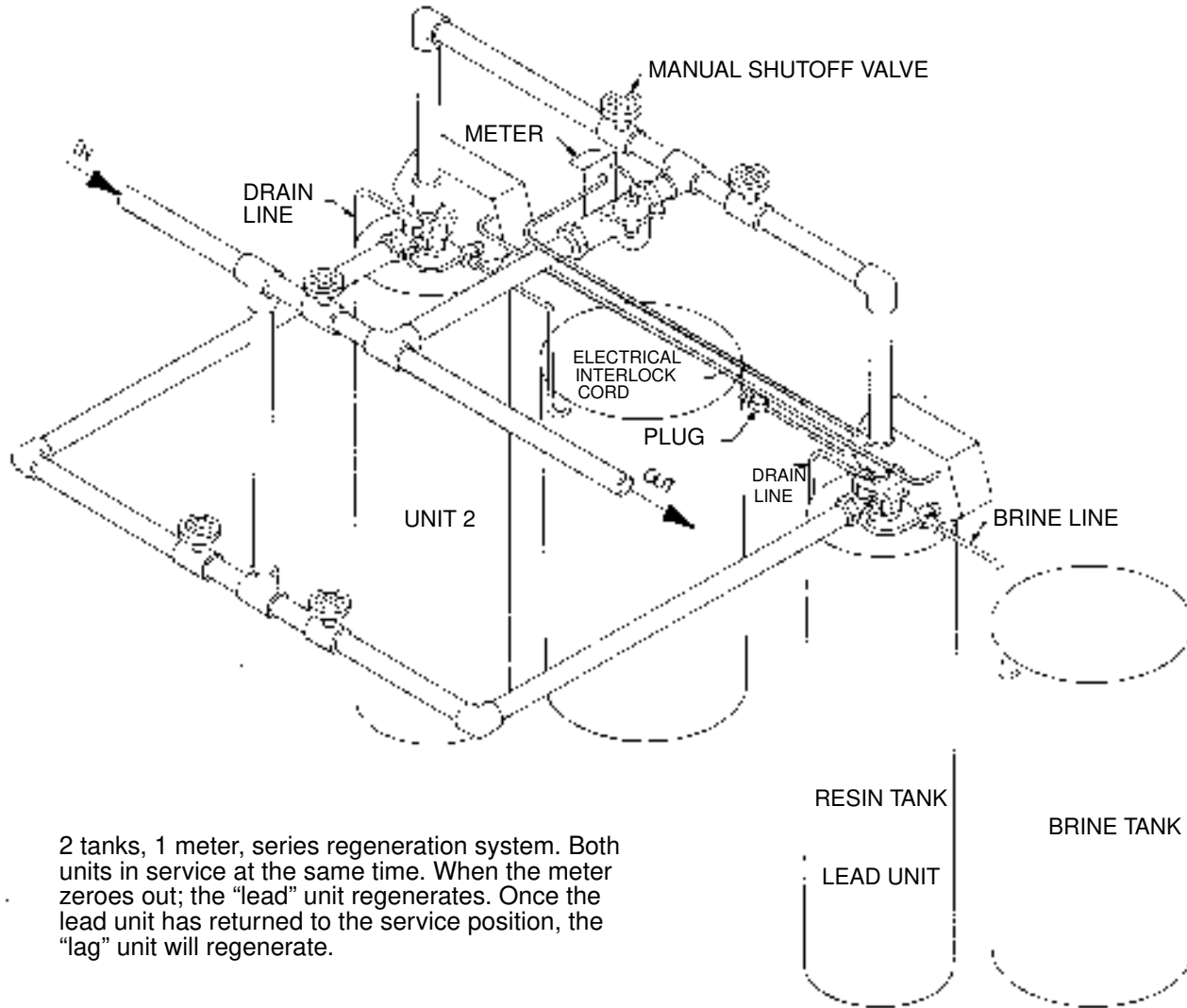

2 tanks, 1 meter, series regeneration system. Both units in service at the same time. When the meter zeroes out; the "lead" unit regenerates. Once the lead unit has returned to the service position, the "lag" unit will regenerate.

# MODEL 2750

## System #7 - Twin Alternator Installation

### With a Remote Meter

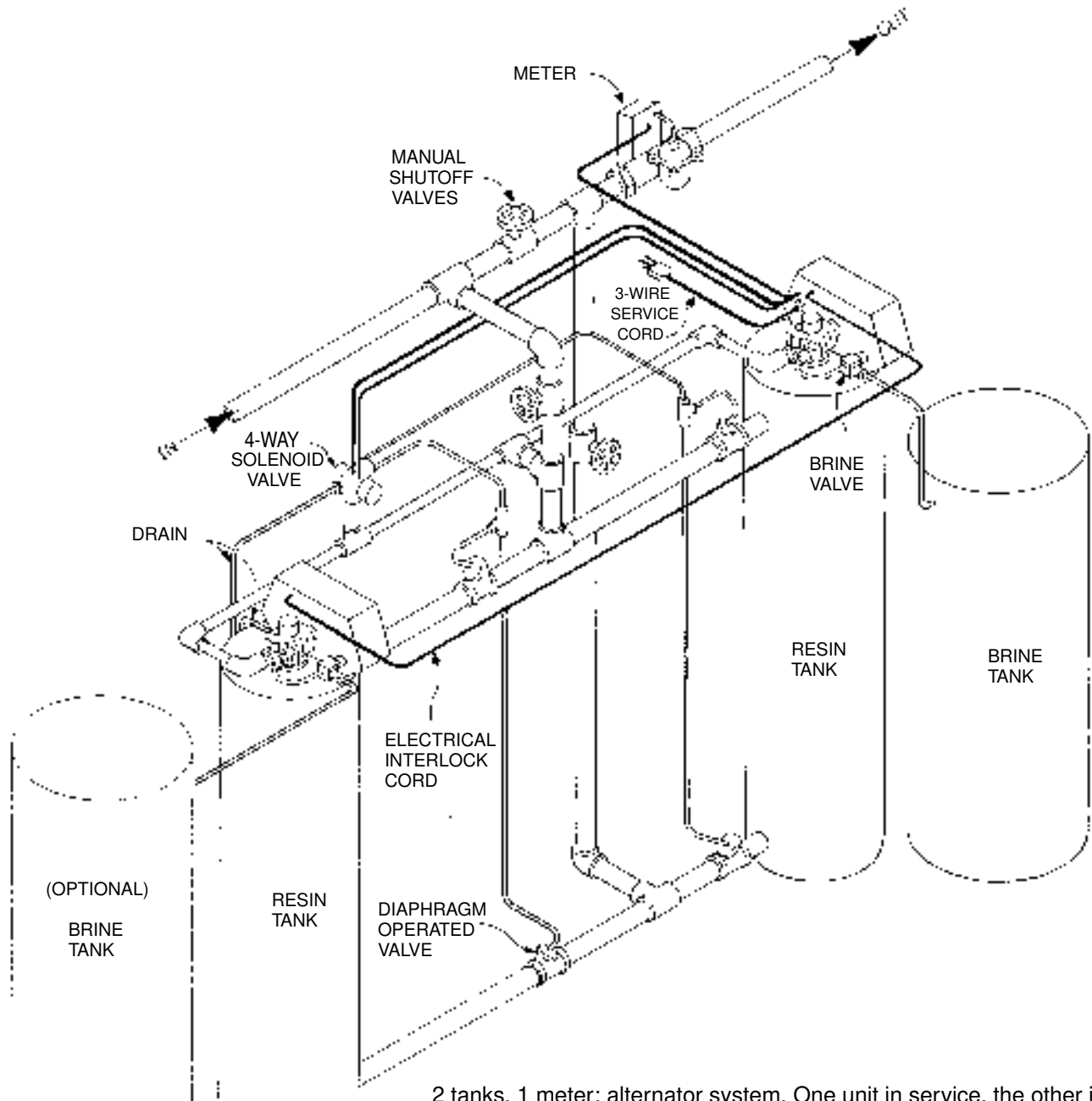

2 tanks, 1 meter; alternator system. One unit in service, the other is on standby. When the meter zero out; the unit in service goes into a regeneration cycle, the stand-by unit, goes into service.

# MODEL 2750 DOWNFLOW

## Service Assemblies

<b>60029</b>	<b>1600 Brine Valve</b> For Illustration, See Page 12
1 . . . . . 10249 . . . . .	Brine Valve Spring
1 . . . . . 10250 . . . . .	Retaining Ring
2 . . . . . 10329 . . . . .	3/8" Brass Nu
2 . . . . . 10330 . . . . .	3/8" Ferrule
2 . . . . . 10332 . . . . .	3/8" Sleeve
1 . . . . . 11749 . . . . .	B/V Stem Guide
1 . . . . . 11982 . . . . .	O-Ring Brine Valve
1 . . . . . 12552 . . . . .	1600 Brine Valve Stem
1 . . . . . 12626 . . . . .	Shut-Off Valve Seat
1 . . . . . 12748 . . . . .	Brine Valve Body
1 . . . . . 12550 . . . . .	Quad Ring

<b>60034-XX</b>	<b>1700 Brine Valve,</b> <b>Specify Refill Rate</b> For Illustration, See Page 11
1 . . . . . 10250 . . . . .	Brine Valve Spring
1 . . . . . 12550 . . . . .	Quad Ring
1 . . . . . 13201 . . . . .	Quad Ring
1 . . . . . 14785 . . . . .	Flow Control Retainer
1 . . . . . 14790 . . . . .	Brine Valve Body
1 . . . . . 14792 . . . . .	Brine Valve End Plug
1 . . . . . 14795 . . . . .	Brine Valve Piston
1 . . . . . 14797 . . . . .	Brine Valve Stem
1 . . . . . 14798 . . . . .	Spacer
2 . . . . . 14811 . . . . .	Piston Seal
1 . . . . . 15310 . . . . .	Brine Valve Spring
1 . . . . . 15517 . . . . .	Stem Guide
1 . . . . . 15414 . . . . .	Nut Ferrule 1/2"
1 . . . . . 16123 . . . . .	Nut 1/2"
1 . . . . . 16124 . . . . .	Ferrule 1/2"

<b>60080-XX</b>	<b>1600 Injector Assembly,</b> <b>Specify Injector Size</b> For Illustration, See Page 8
1 . . . . . 10227 . . . . .	Injector Screen
1 . . . . . 11893 . . . . .	Injector Cap
1 . . . . . 10229 . . . . .	Injector Cover Gasket
1 . . . . . 10328 . . . . .	90° Elbow 1/4" NPT x 3/8" Tube
2 . . . . . 10692 . . . . .	Screw
1 . . . . . 10913 . . . . .	Injector Nozzle
1 . . . . . 10914 . . . . .	Injector Throat
1 . . . . . 11475 . . . . .	Injector Body Gasket
1 . . . . . 17776 . . . . .	Injector Body

<b>60381-XX</b>	<b>1700 Injector Assembly,</b> <b>Specify Injector Size</b> For Illustration, See Page 8
1 . . . . . 11893 . . . . .	Injector Cap
1 . . . . . 10229 . . . . .	Injector Cover Gasket
1 . . . . . 17777 . . . . .	Injector Body
1 . . . . . 14801 . . . . .	Injector Nozzle
1 . . . . . 14802 . . . . .	Injector Throat
1 . . . . . 14803 . . . . .	Injector Screen
2 . . . . . 14804 . . . . .	Screw
1 . . . . . 14805 . . . . .	Injector Body Gasket

<b>60090-HF</b>	<b>2750 Piston Assembly</b> For Illustration, See Page 8
1 . . . . . 10209 . . . . .	Quad Ring, -010
1 . . . . . 10234 . . . . .	O-Ring, -024
1 . . . . . 10598 . . . . .	End Plug Assembly
1 . . . . . 10909 . . . . .	Pin, Link
1 . . . . . 14451 . . . . .	Piston, 2750
1 . . . . . 14452 . . . . .	Piston Rod

<b>60090-HF</b>	<b>2750 Piston Assembly</b>
1 . . . . . 10598 . . . . .	End Plug Assy.
1 . . . . . 10909 . . . . .	Pin, Link
1 . . . . . 14451 . . . . .	Piston, 2750
1 . . . . . 14452 . . . . .	Piston Rod

<b>60091-HF</b>	<b>2750 Piston Assy., Hot Water</b>
1 . . . . . 10598-01 . . . . .	End Plug Assy., Hot Water
1 . . . . . 14451 . . . . .	Piston 2750
1 . . . . . 14452 . . . . .	Piston Rod
1 . . . . . 10909 . . . . .	Pin, Link

<b>60121</b>	<b>Seal &amp; Spacer Kit, 2750</b>
6 . . . . . 10545 . . . . .	Seal, Piston
1 . . . . . 10757 . . . . .	End Spacer
5 . . . . . 11451 . . . . .	Spacer, 12 Hole

<b>60122</b>	<b>Seal &amp; Spacer Kit, 2750</b> <b>Hot Water</b>
6 . . . . . 10545 . . . . .	Seal, Piston
1 . . . . . 10757B . . . . .	End Spacer
5 . . . . . 16589 . . . . .	Spacer, HW



# MODEL 2750

---

## Service Assemblies (Cont'd.)

---

<b>60050-21</b>	<b>2750 Drive Assy., 120V</b>	<b>6071 0-XX</b>	<b>BLFC, 1" Specify Flow Rate Range 8.0 - 25.0 GPM</b>
2.....10218.....	Micro Switch		
1.....10250.....	Retaining Ring	<b>60391</b>	<b>2750 Meter Assy., STD</b>
2.....10302.....	Insulator	<b>60392</b>	<b>2750 Meter Assy., EXT</b>
2.....10338.....	Pin, Roll 3/32 x 7/8	<b>60301</b>	<b>3000 12 Day Timer, Specify Voltage</b>
1.....10621.....	Link	<b>60303</b>	<b>3200 Clock Timer, Specify Voltage</b>
1.....10769.....	Motor, Drive 1 20V	<b>60306</b>	<b>3210 Delay Timer, Specify Voltage</b>
1.....10774.....	Bracket, Motor Drive Side	<b>60307</b>	<b>3220 Immed Timer, Specify Voltage</b>
5.....10872.....	Screw, Hex Washer 8-32 x 5/16		
1.....11667.....	Wire Harness, Drive Motor		
1.....11826.....	Bracket, Sensor Motor		
1.....12576.....	Cam, Drive STF		
1.....12777.....	Cam, Shut-Off Valve		
1.....13366.....	Bearing, Drive		
2.....14923.....	Screw, Pan HD Mach 4-40 x 1		
1.....17904.....	Bushing, Heyco		
<b>60365-XX</b>	<b>Brass DLFC 3/4" NPT Specify Flow Rate Range 1.2 - 7.0 GPM</b>		

